

SLIDING DOOR DRIVE

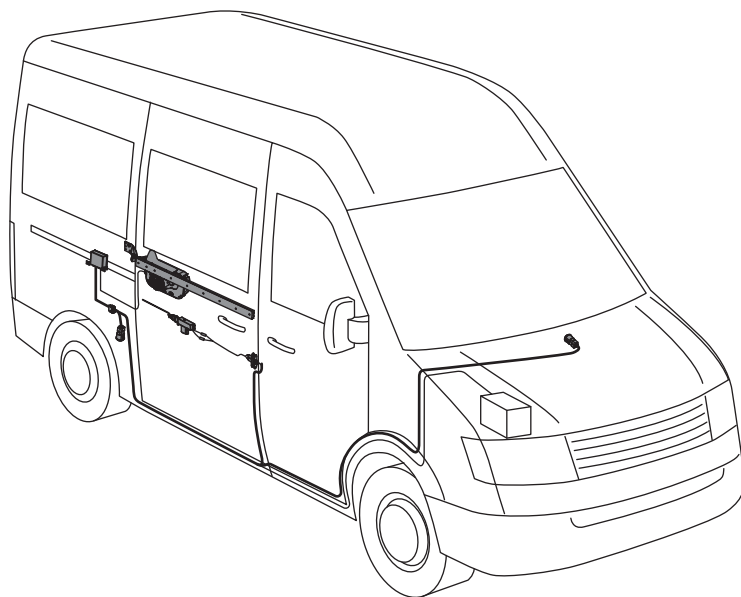

OPERATIONS MANUAL



IVECO DAILY
FIAT DUCATO 240; 250
FORD TRANSIT
TOYOTA HIACE
GASELLE, BARGUZIN, SOBOL
PEUGEOT BOXER / CITROEN JUMPER
MERCEDES SPRINTER 906 / VOLKSWAGEN CRAFTER



We congratulate you upon the acquiring of CROCO sliding door drive! We hope that its operation will bring you in a good mood.

If you have any questions concerning maintenance and repair, please contact authorized representatives of the manufacturing plant ADOR Ltd. If you have other questions or suggestions, please contact us on **sales@ador.su** and **marketing@ador.su**



NOTE!



The drive has undergone safety tests according to All-Union State Standard R 41.107-99.

Inattentive using of the drive can represent a danger. A moving door can injure a passenger, especially a child.

A minibus's driver bears responsibility for inattentive using of the drive.

Information stickers must be positioned in prescribed places (picture 3), inscriptions on the stickers must be seen clearly.

Read information about your actions in case of an accident or operation failure of a drive. This is a guarantee of your and your passengers' safety.



IMPORTANT!



Open and close the door only in a completely motionless state of a minibus. The violation of this rule is DANGEROUS for passengers and can lead to premature wear and damage of the door drive.

CROCO drive is designed for opening and closing doors in minibuses working as taxi buses. The models of the buses are listed on the manual cover.

Basic characteristics	
Power consumption (nominal)	70 W
Power consumption (maximum)	250 W
Time of door opening (depends on the width settings)	~2 sec.
Time of door closing (depends on the width settings)	~2 sec.
External temperatures	-25 - +40
Maximum allowed angle of bus ascent when the door will close	10°
Speed of door opening	~0.3 m/sec
Speed of door closing	~0,3 м/сек.
Resource	Not less than 150 000 opening/closing cycles

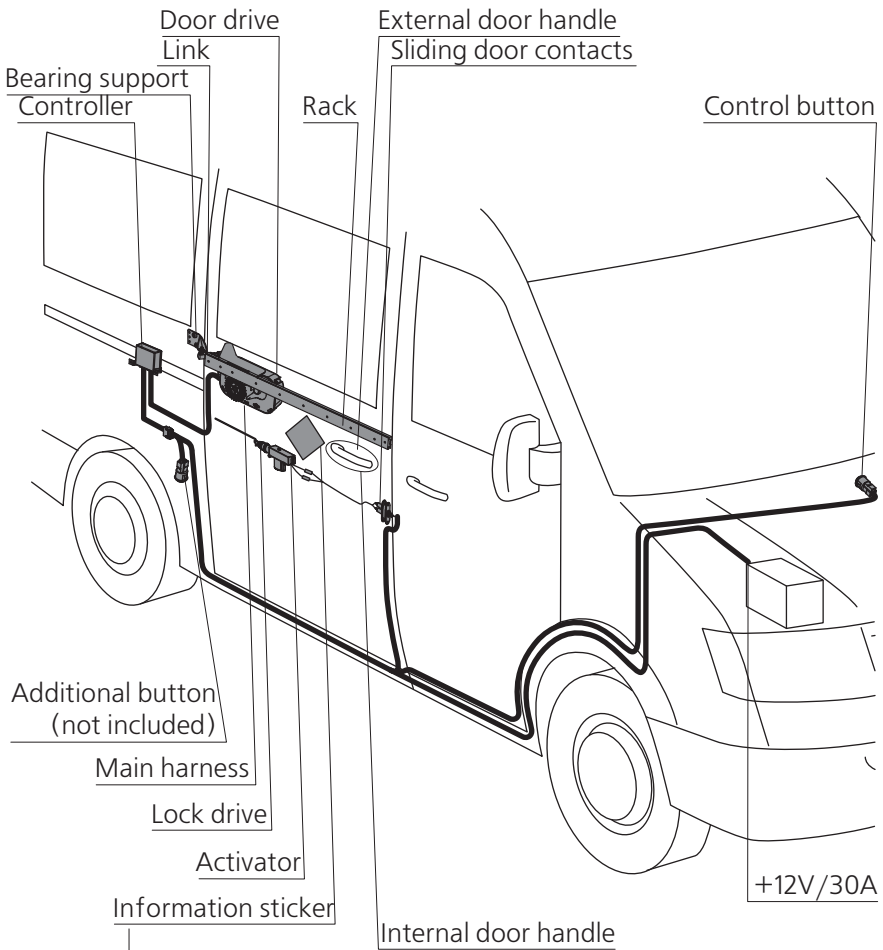

- Rapidly wearing parts
- Sliding door contacts
 - Control button

4 DRIVE FUNCTIONS, DESCRIPTION OF OPERATION

OPENING AND CLOSING THE DOOR

Press the control button for ~0.5 sec. The door will start moving after you release the button.

AUTOMATIC ROLL-BACK

If the door pushes against an obstacle while it is closing, it will stop automatically and roll back.

STOPPING THE DOOR

Press the control button one time to stop the door while it is moving.

ADJUSTMENT OF THE WIDTH OF DOOR OPENING

Open the door. Move it to the required position by hand. Press the control button for ~10 sec. until you hear 2-times sound signal. Release the button. Now the drive will automatically remember the adjusted width of the opening.

SLIDING DOOR FIXING

The drive can operate in 2 modes:
with fixing (factory settings) picture 4).
without fixing (picture 3).

To change the mode to operating without fixing press the control button for ~15 sec. until you hear 3 long sound signals. Release the button.



NOTE



Operating mode without fixing is used if there is a lock drive. Emergency opening of the door from the outside is possible in this operating mode.

RETURN TO FACTORY SETTINGS

Press the control button for ~20 sec. until you hear 4-times sound signal. Release the control button. All drive settings will return to factory settings.



NOTE



The drive settings will automatically return to factory settings in case of power outage.

DRIVE FUNCTIONS, DESCRIPTION OF OPERATION 5

EMERGENCY DOOR OPENING FROM THE INSIDE

- 1) Turn the door handle and hold it
- 2) Move the drive 10 cm to the left
- 3) Open the door by hand

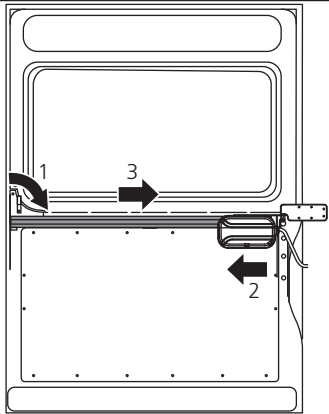

Pic. 1

EMERGENCY DOOR OPENING IN THE OPERATING MODE WITHOUT FIXING

- 1) Pull the back side of the door
- 2) Open the door by the operational handle

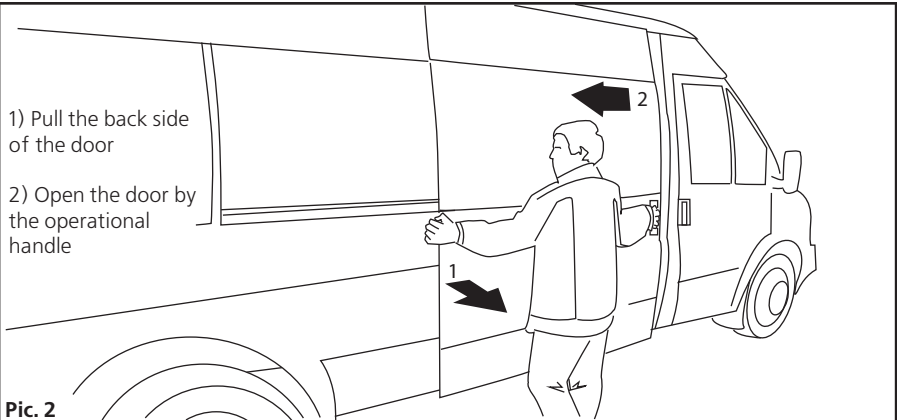

Pic. 2

Operating mode without fixing

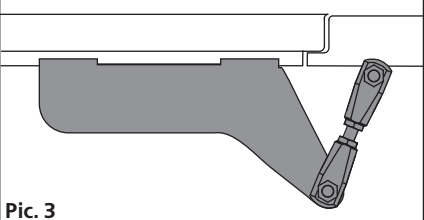

Pic. 3

Operating mode with fixing

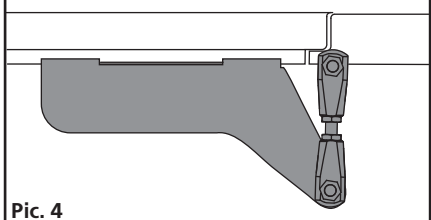

Pic. 4

6 DRIVE FUNCTIONS, DESCRIPTION OF OPERATION

CHANGING TO MANUAL OPERATING MODE

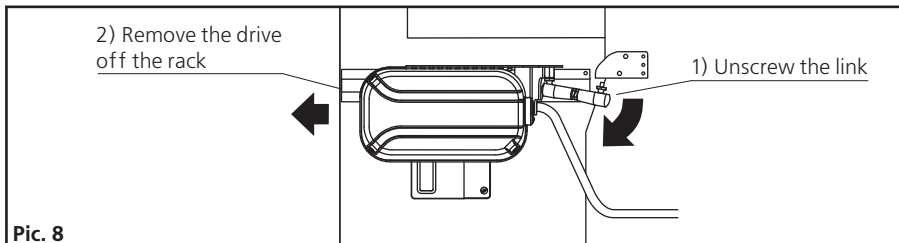
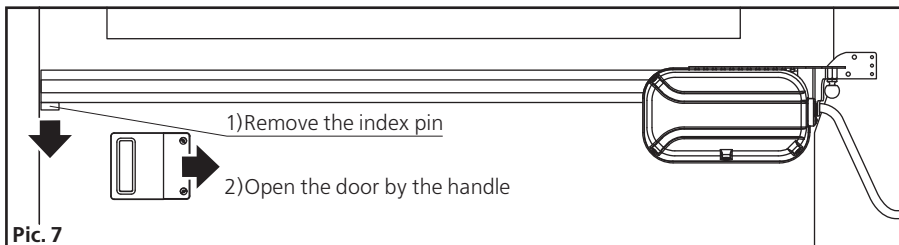
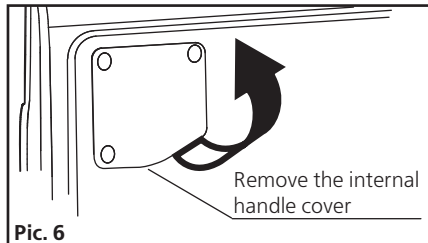
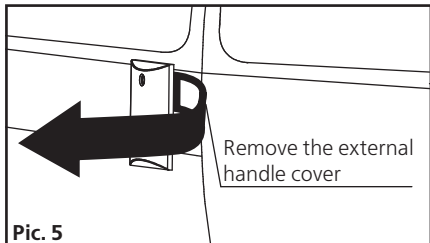

To ensure long-term operation of the drive you have to undergo regular maintenance at ADOR authorized representatives' workshops in accordance with table 1. The minibus's owner has to do self-maintenance in accordance with table 2.

MAINTENANCE AT ADOR REPRESENTATIVES' WORKSHOPS

Table 1

Nº	Description of work	1 month	4 months	8 months	12 months	Further maintenance
1	General examination of parts and assemblies of the drive and sliding door	+	+	+	+	every 2 months
2	Checking wear of sliding door contacts (replacement if necessary)	-	+	+	+	every 2 months
3	Tightening of fixation screws of the rack to the door	+	+	+	+	every 2 months
4	Checking the sliding door against its frame (adjustment if necessary)	+	+	+	+	every 2 months
5	Checking electric connections of the wire harness of the drive	-	+	+	+	every 2 months
6	Checking length of the link (adjustment if necessary)	+	+	+	+	if necessary
7	Checking fixation of the back bearing support	+	+	+	+	every 2 months
8	Checking working condition of the drive belt (adjustment of tension or replacement if necessary)	+	+	+	+	every 2 months
9	Checking clearance between the rack and the pinion (adjustment if necessary)	+	+	+	+	every 4 months

SELF-MAINTENANCE

Table 2

№	Description of work	Frequency
1	Cleaning and greasing the rack (WD-40)	every week
2	Cleaning and greasing the rack guide and door carriage rollers (WD-40)	every week
3	Greasing sliding door contacts (picture 9)	every week
4	Checking wear and replacement of sliding door index pins (picture 9)	every 4 months

Maintenance in ADOR authorized representatives' workshops requires payment. It is carried out in accordance with the schedule and the representative's rates. During the maintenance the owner must show a warranty certificate.



IMPORTANT!



The first check-up is carried out in 1 month after installation.

After the check-up a specialist makes a note about performance of work on page 12.



IMPORTANT!



If drive operation is accompanied by knocks, clicks, scraping, door vibration, please contact ADOR authorized representatives immediately.

DISPOSITION OF SLIDING DOOR INDEX PINS AND CONTACTS

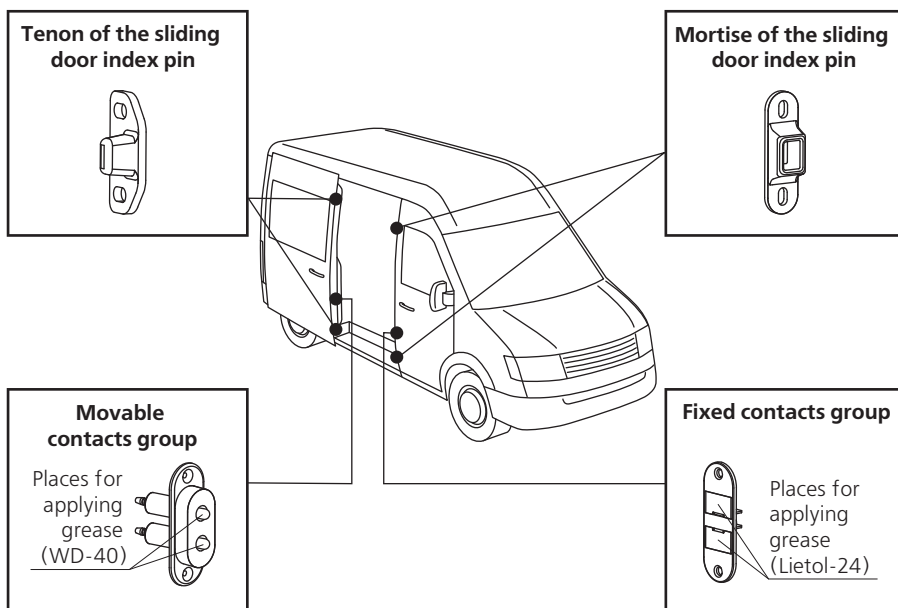

10 MANUFACTURER'S GUARANTEE OBLIGATIONS

ADOR gives guarantee for this drive for 12-month period or 150,000 opening/closing cycles in a minibus working as a taxi bus.

The guarantee does not cover rapidly wearing parts:

- Sliding door contacts (operating life 6 months);
- Control button (operating life 6 months).

THE GUARANTEE IS NOT GIVEN IN THE FOLLOWING CASES:

- If the drive is installed not by ADOR authorized representative;
- If there is no warranty certificate or warranty certificate is filled in incorrectly. The serial number on the sticker in the warranty certificate and on the parts is damaged;
- If you did not do the check-up or you missed the term of a regular check-up at ADOR authorized representative's workshop;
- If the drive is damaged due to its incorrect servicing and / or operation;
- If unauthorized connection to the electric diagram of the device is revealed, as well as self-made installation of additional equipment influencing drive operation. The exception in this case is installation of the equipment carried out by ADOR authorized representative and a proper note made on a servicing page.
- If signs of self-made repair are revealed as well as drive damages due to a car accident.

.....

(VIN) _____

Drive installation date _____

Guarantee period is 12 month starting from the installation date.

Installation carried out by _____
/Name / Signature/

Installation checked by _____
/Name / Signature/

Address and phone number of the installing company

_____ (Stamp of the installing company) _____

Hereby I acknowledge that I do not have any complaints about quality of the product and its installation. I have read and understood the rules of drive use and guarantee obligations of the installing company as well as the warning of potential danger of the device on page 1.

_____ (Buyer's signature)

DEAR CUSTOMER!

If you have any questions concerning guarantee maintenance and post-guarantee maintenance, please contact us at:

REGISTERED OFFICE:

61, Borkovskaya Str., Togliatty, Russia, 445043

POSTAL ADDRESS:

PO Box 1982, 26, Marshal Zhukov Str., Togliatty, Russia, 445051

<http://www.ador.su>

e-mail: office@ador.su

Phone number: +7 8482 20 20 50 (08.00-18.00 Moscow time)

SERVICE DEPARTMENT		
Service department	(8482) 20-20-50 (ext.123) (8482) 55-15-50	service@ador.su
SALES DEPARTMENT		
Head of Sales department	(8482) 20-20-50 (ext.130)	sales@ador.su
Office manager	(8482) 20-20-50 (ext.126)	office@ador.su
Sales managers	(8482) 20-20-50 (ext. 127,128,129,131,132)	sales1@ador.su sales2@ador.su sales3@ador.su sales4@ador.su sales5@ador.su