

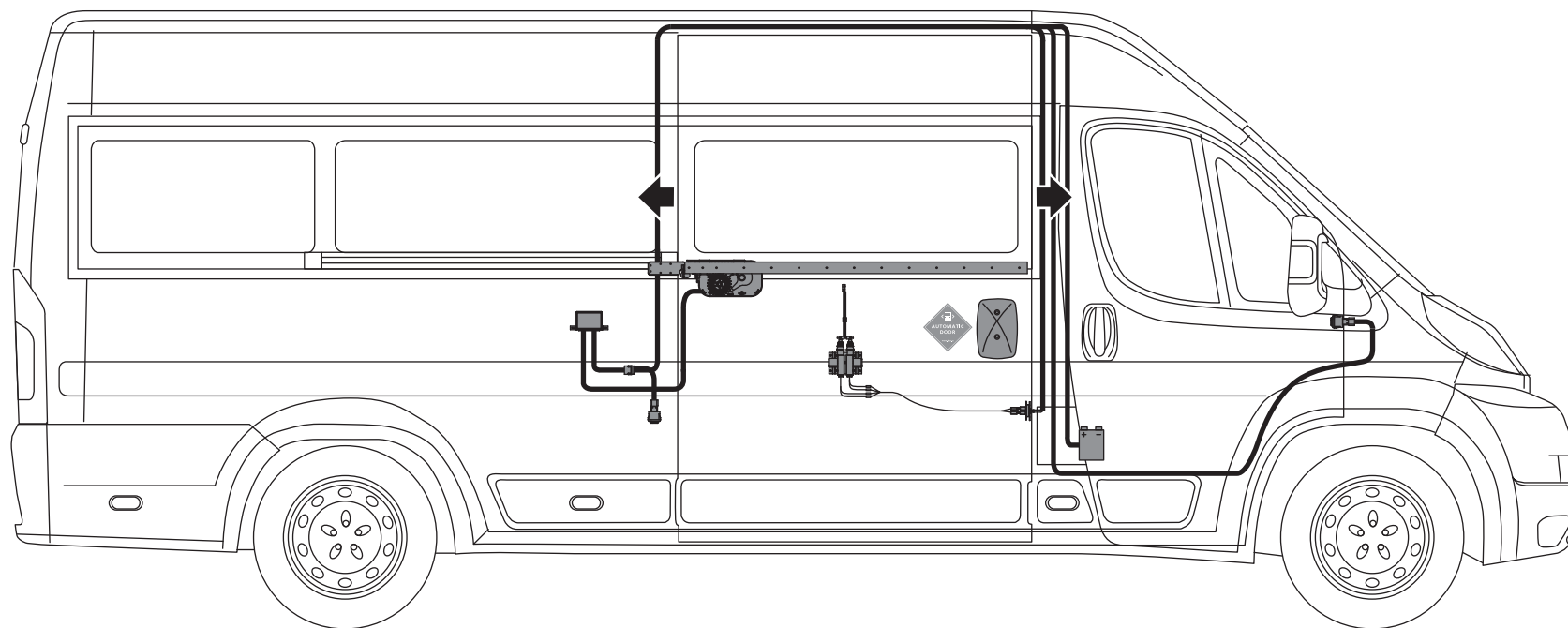

RACK AND PINION DRIVE ADOR CROCO INSTALLATION MANUAL

19.06.2013

PEUGEOT BOXER / CITROEN JUMPER / FIAT DUCATO (250)



| | |
|--|----|
| 1.1 General information | 4 |
| 1.2 General information, precautions and tool list | 6 |
| 2.1 Door adjustment | 7 |
| 2.2 Main harness | 8 |
| 2.3 Connection diagram of rack and pinion drive | 9 |
| 2.4 Main harness installation | 10 |
| 2.5 Controller installation and connection of ground wire "-" terminal | 11 |
| 2.6 Connection of positive wire to positive terminal of accumulator | 12 |
| 2.7 Installation of lock drive and activator harness | 13 |
| 2.8 Disposition of control button and sliding door contacts | 15 |
| 2.9 Installation of rack and padding on the door | 16 |
| 3.0 Installation of the rack on the door | 18 |
| 3.1 Bearing support installation | 19 |
| 3.2 Preparing to door drive installation | 20 |
| 4.0 Door drive starting up | 21 |
| 4.1 Door drive adjustment | 22 |
| 4.2 Installation of drive cover and decorative edge | 23 |
| 4.3 Disposition of information sticker | 24 |
| 4.4 Installation of external handle cove | 25 |
| 4.5 Drive control and settings | 26 |

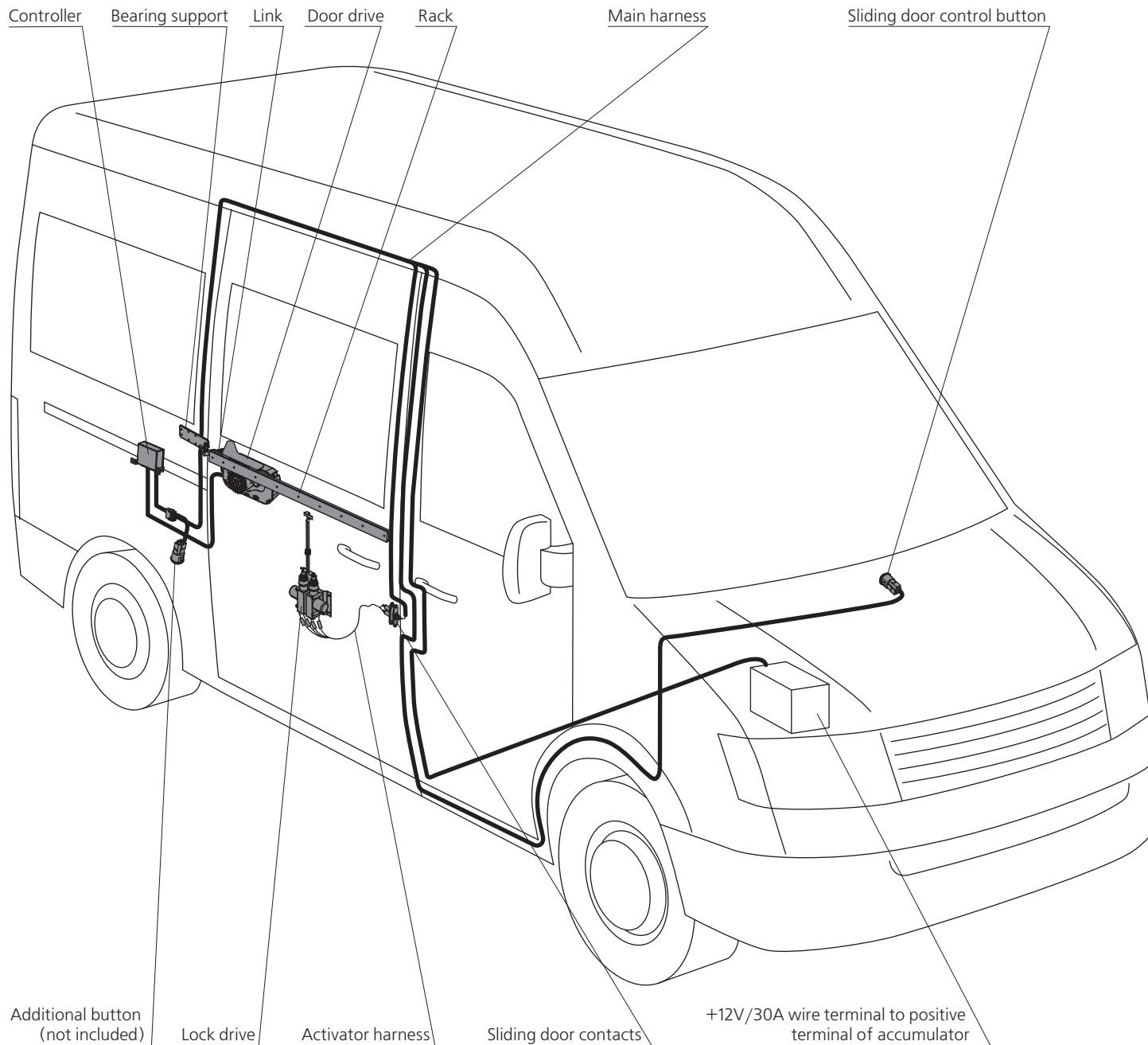

This model is suitable for opening and closing sliding doors in minibuses PEUGEOT BOXER, CITROEN JUMPER, FIAT DUCATO maxi.

Disposition of assemblies and parts of the drive is shown on the model of a standard minibus.



NOTE



This manual describes installation of the drive with maximum specifications. If you install a door drive without any additional options, just omit unnecessary paragraphs of the manual.

BASIC TECHNICAL CHARACTERISTICS

CROCO drive is designed for opening and closing doors in minibuses working as taxi buses. The models of the buses are listed on the manual cover.

| | |
|--|--|
| Power consumption (nominal) | 70 W |
| Power consumption (maximum) | 250 W |
| Time of door opening (depends on the width settings) | 2 sec. |
| Time of door closing (depends on the width settings) | 2 sec. |
| External temperatures | -25 - +40 |
| Maximum allowed angle of bus ascent when the door will close | 10° |
| Resource | Not less than 150 000 opening/closing cycles |



NOTE



Long-lasting and trouble-free operation of ADOR drive depends on the quality of installation. That is why installation is carried out in specialized workshops of ADOR's representatives.

OPERATING CONTROL

ADOR drive is an electromechanical device which operates being connected to the in-vehicle network. The drive consists of two main parts: lock drive and door drive. The lock drive opens the lock and the door drive opens and closes the door. Drive control can be carried out by means of

- **Main control button** which controls the door functions and the system settings.
- **Rack drive remote control** which controls the door functions.

MOTOR DRIVE FUNCTIONS:

- **Opening and closing the door**
- **Automatic roll-back of the door**
- **Door stopping**
- **Sound signal**
- **Operating mode with and without fixing the sliding door**
- **Adjustment of the opening width**

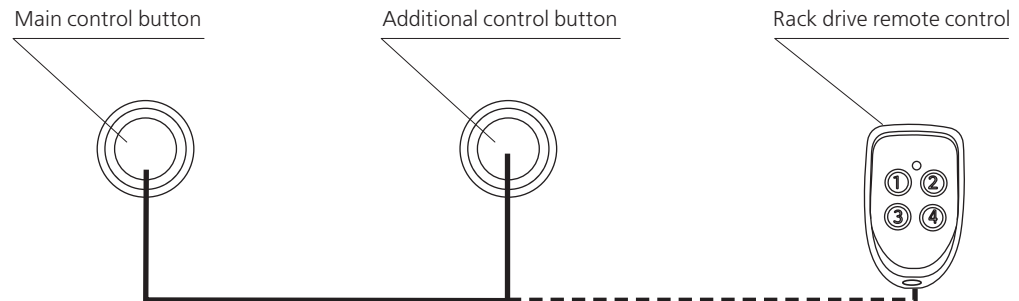
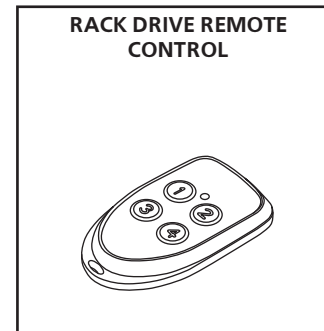
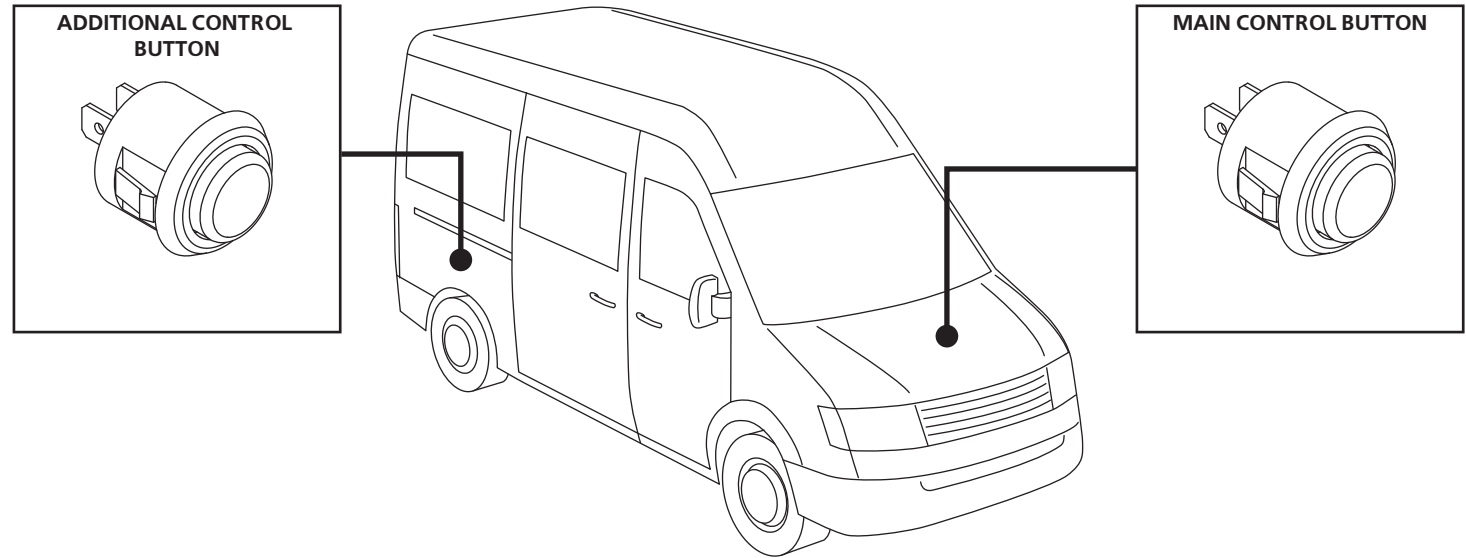

PRECAUTIONS

Drive installation involves refining of existing body parts of a minibus. All body parts of a minibus are made of sheet metal, so there is a high probability of being cut by sharp edges appearing after refinement or by sharp parts of mechanical hand tools. During drive installation follow safety procedures while working with mechanical hand tools, blunt sharp edges of drilled holes. Use only tools in good working condition. During installation keep your working place clean, especially in the bus saloon. Before starting installation prepare all the necessary tools and parts, take away unnecessary things.

Trouble-free operation, reliability and operating life of the drive depend on precise accomplishments of the instructions given. It also depends on the precision of relative disposition of drive parts and assemblies. Before drilling fixation holes put the marks for drilling thoroughly, check correct disposition of a concrete part or assembly and only after that drill the holes.

This drive is an electromechanical device, so alongside metalwork there is also wire installation and connection to power supply. That is why electrical safety procedures must be followed. While connecting contacts, keep your hands and working place clean. This will provide reliable contacts connection and trouble-free operation of the drive as a whole.

TOOL LIST

| | |
|--|-------|
| Clip withdrawal tool | 1 |
| Head stock 10-17 mm | 1 |
| setRiveter | 1 |
| Riveter for pull-out nuts GESIPA GBM10 | 1 |
| Centre punch | 1 |
| Set of combination wrenches | 1 set |
| Metal ruler | 1 |
| Hammer | 1 |
| Set of hexagon wrench tools | 1 |
| Set of star wrench tools Torx | 1 |
| Knife | 1 |
| Flat tipscrewdriver | 1 |
| Cross tip screwdriver | 1set |
| Pliers | 1 set |
| Wire for tightening | 3m. |

| | |
|---|----------|
| Drill bits - 2,5; 3,2; 5; 6,5; 9; | 1 |
| Step-shaped drill 4-24 mm | 1 |
| Slack adjuster | 1 |
| Electrical extension cord | 1 |
| Lamp | 1 |
| Sliding calipers | 1 |
| Electric drill | 1 |
| Hack saw | 1 |
| Multimeter | 1 |
| Sidescutter | 1 |
| Rivet nut | 15 |
| Rubber solvent petrol | 1bottle. |

After drilling holes burrs are left on the hole edges and paint coating of the body is inevitably damaged. In some places which require additional processing the following symbols will be used:

- ☉ – Remove burrs off the edges
- ☉ – Blunt sharp edges
- ☉ – Coat the edge with rust-proof liquid

Example: cover the edges of the holes with rust-proof liquid

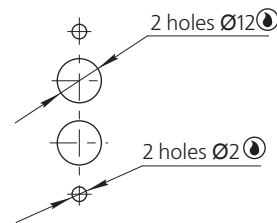

2.1 DOOR ADJUSTMENT

Before installing the drive, adjust the minibus's door because its adjustment influences the drive operation.

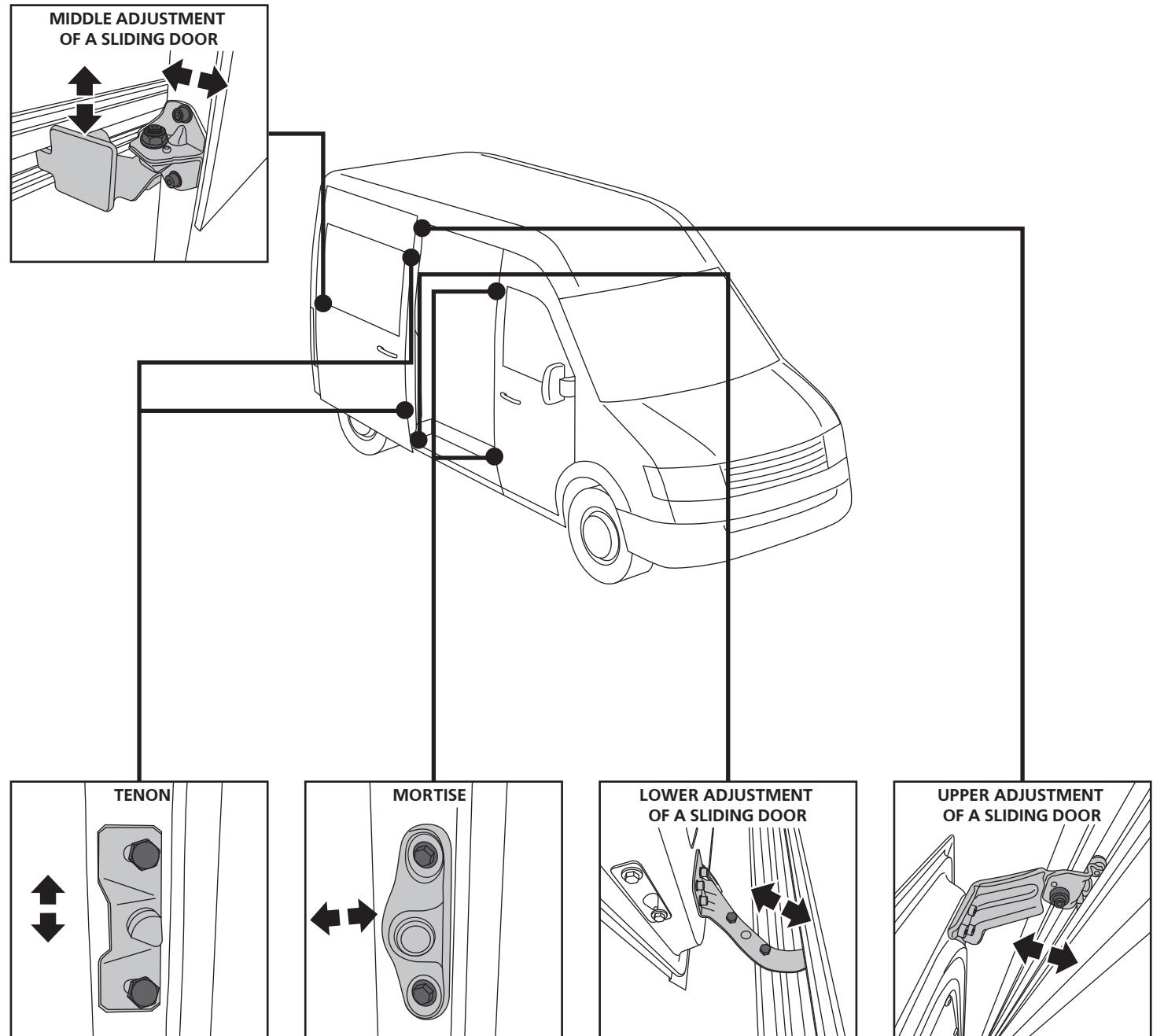

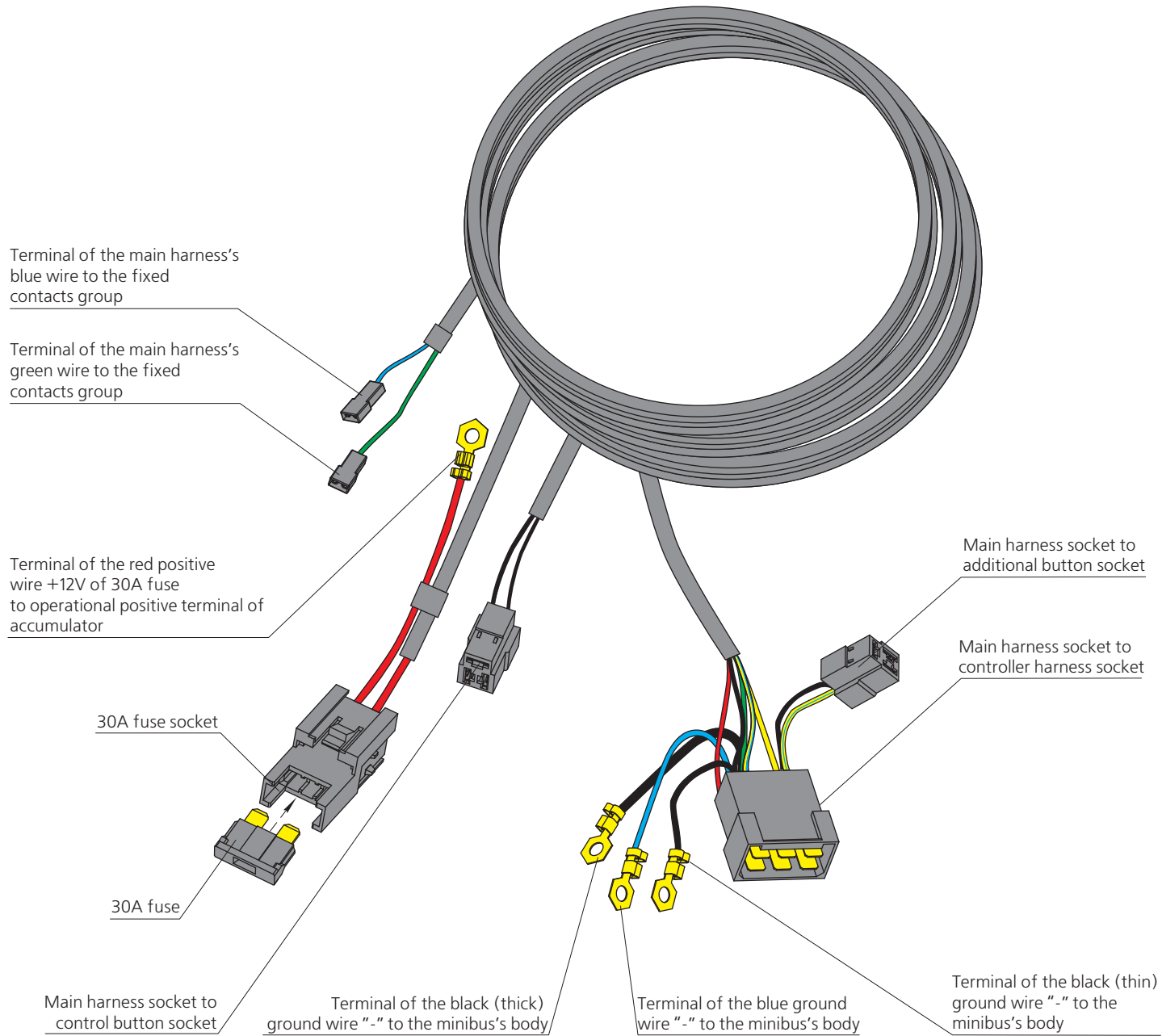

2.3 CONNECTION DIAGRAM OF RACK AND PINION DRIVE

1. Rack drive
2. Controller
3. Drive socket (black, red, grey and black, blue and black, grey and white, red and white)
4. Controller harness socket (black, red, grey and black, blue and black, grey and white, red and white)
5. Controller harness socket (red, black, green, blue and yellow, yellow)
6. Main harness socket (green, red, blue, black (thick), black (thin), blue and yellow)
7. Terminals of the ground wires "-" (black (thick), black (thin), blue) to the minibus's body
8. Main harness
9. Additional button
10. Additional button socket (black, blue and yellow)
11. Terminal of the main harness's blue wire to the fixed contacts group
12. Terminal of the main harness's green wire to the fixed contacts group
13. Fixed contacts group
14. Movable contacts group
15. Terminal of the activator harness's blue wire to the movable contacts group
16. Terminal of the activator harness's green wire to the movable contacts group
17. Terminal of the activator harness's blue wire
18. Terminal of the activator harness's green wire
19. Lock drive
20. Activator harness
21. Terminal of 30A fuse red wire
22. 30A fuse
23. Terminal of +12V red positive wire to operational positive terminal of accumulator
24. Main control button
25. Main control button socket (black, blue and yellow)
26. Terminal of activator blue wire
27. Terminal of activator green wire

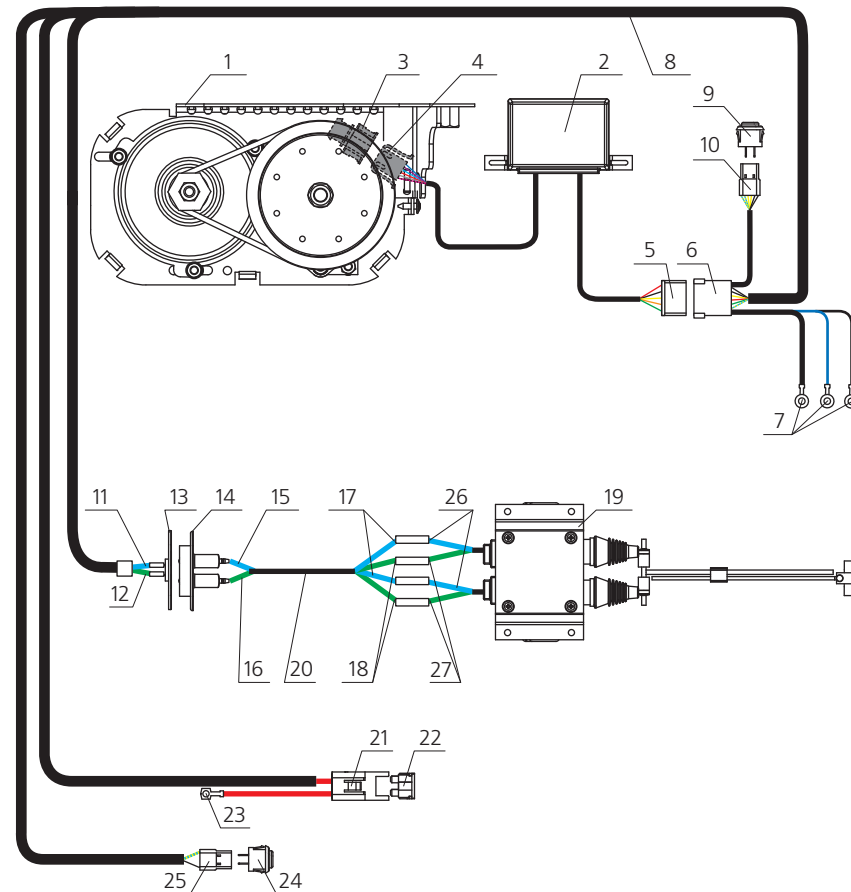

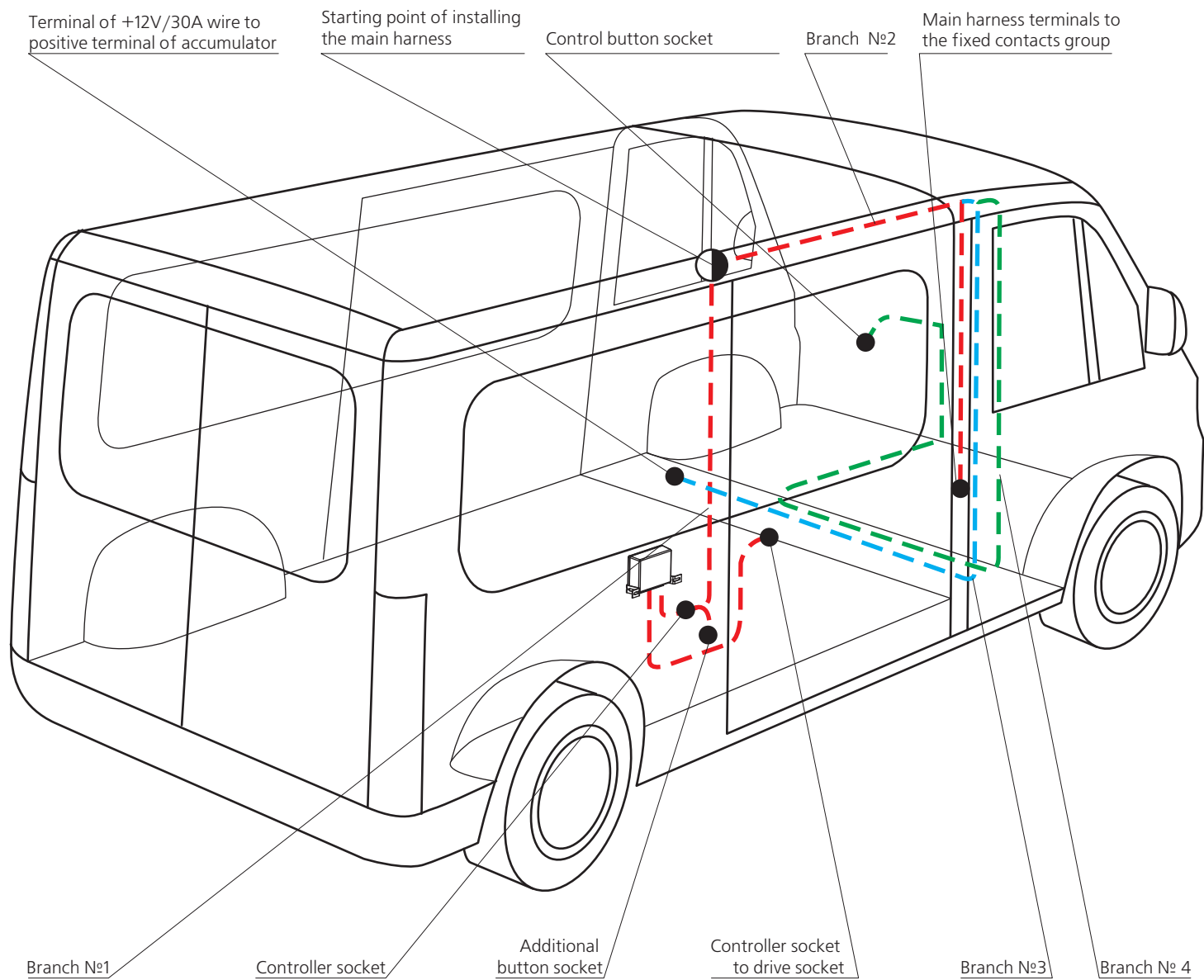

When installing the main harness use steel wire to conceal the harness in the hidden places. Disposition of the main harness is shown in the picture. Be careful while installing the harness: insulating material must not be damaged.

Begin installing the main harness at the starting point as shown in the picture in the following order:

- Extend branch №1
- Extend branch №2
- Extend branch №3
- Extend branch №4

When extending branch №1 disconnect socket from the main harness. Do not forget to mark the colours of the wires in the socket.

2.5 CONTROLLER INSTALLATION AND CONNECTION OF GROUND WIRE "-" TERMINAL 11

Place the controller in the pocket of the body pillar and fix it with 2 self-driving screws 4.6-16 from the metalware set.

To fix the ground wire "-" terminal of the main harness drill a hole $\varnothing 6.5$ mm in any place on the body wall as shown in picture 1. Remove the paint off the metal around the hole to ensure good contact as shown in picture 2. Fix the ground wire "-" terminal using bolt M6-14, toothed washer and nut M6 as shown in picture 3. The toothed washer must be placed between the terminal and the minibus's body.

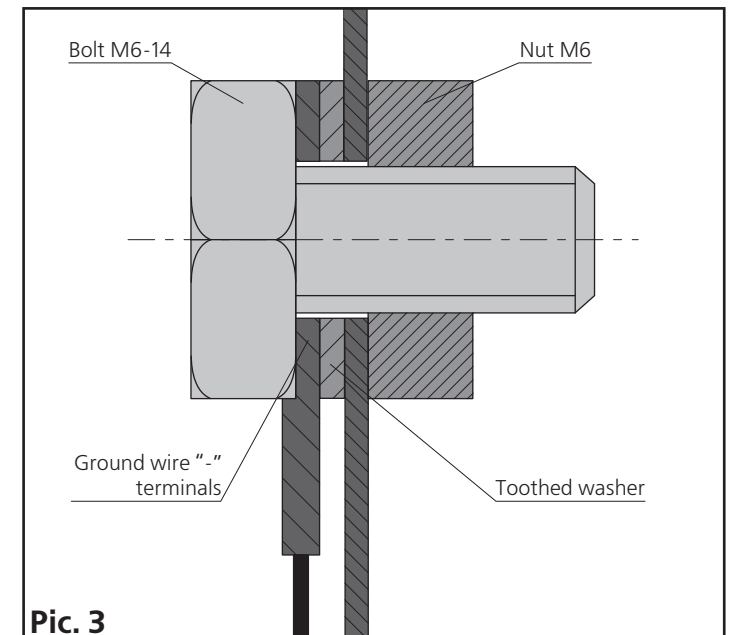
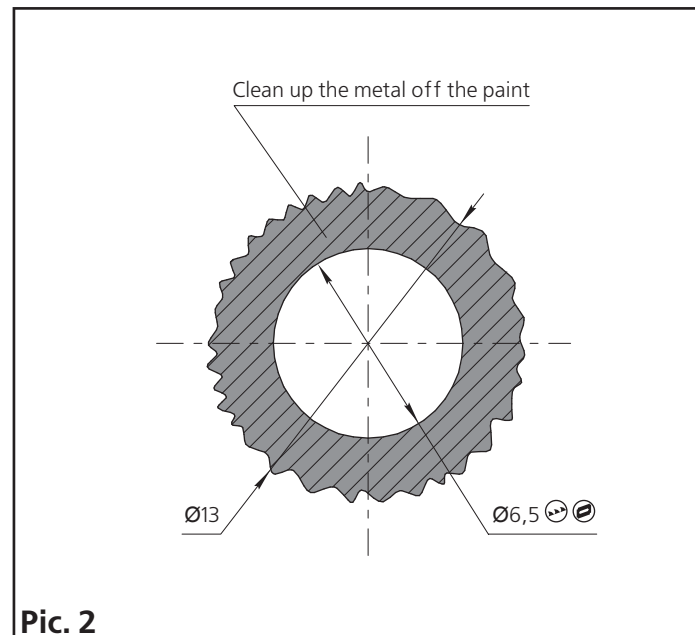
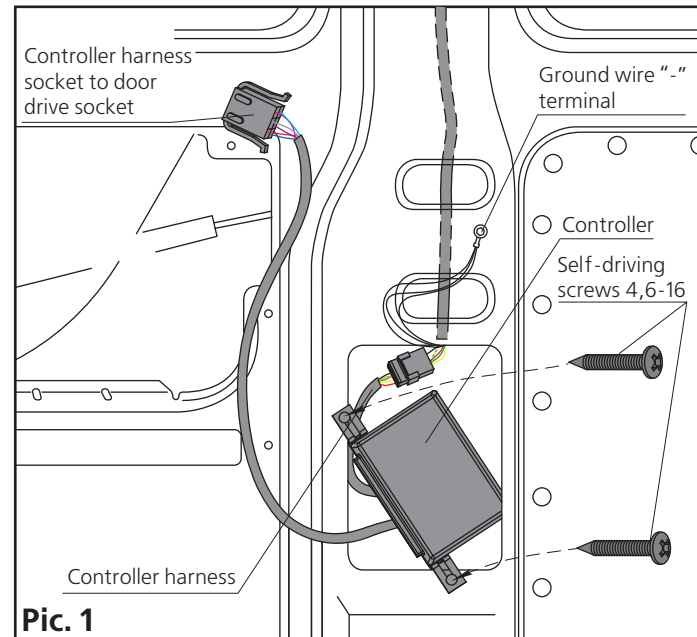

12 2.6 CONNECTION OF POSITIVE WIRE TO POSITIVE TERMINAL OF ACCUMULATOR

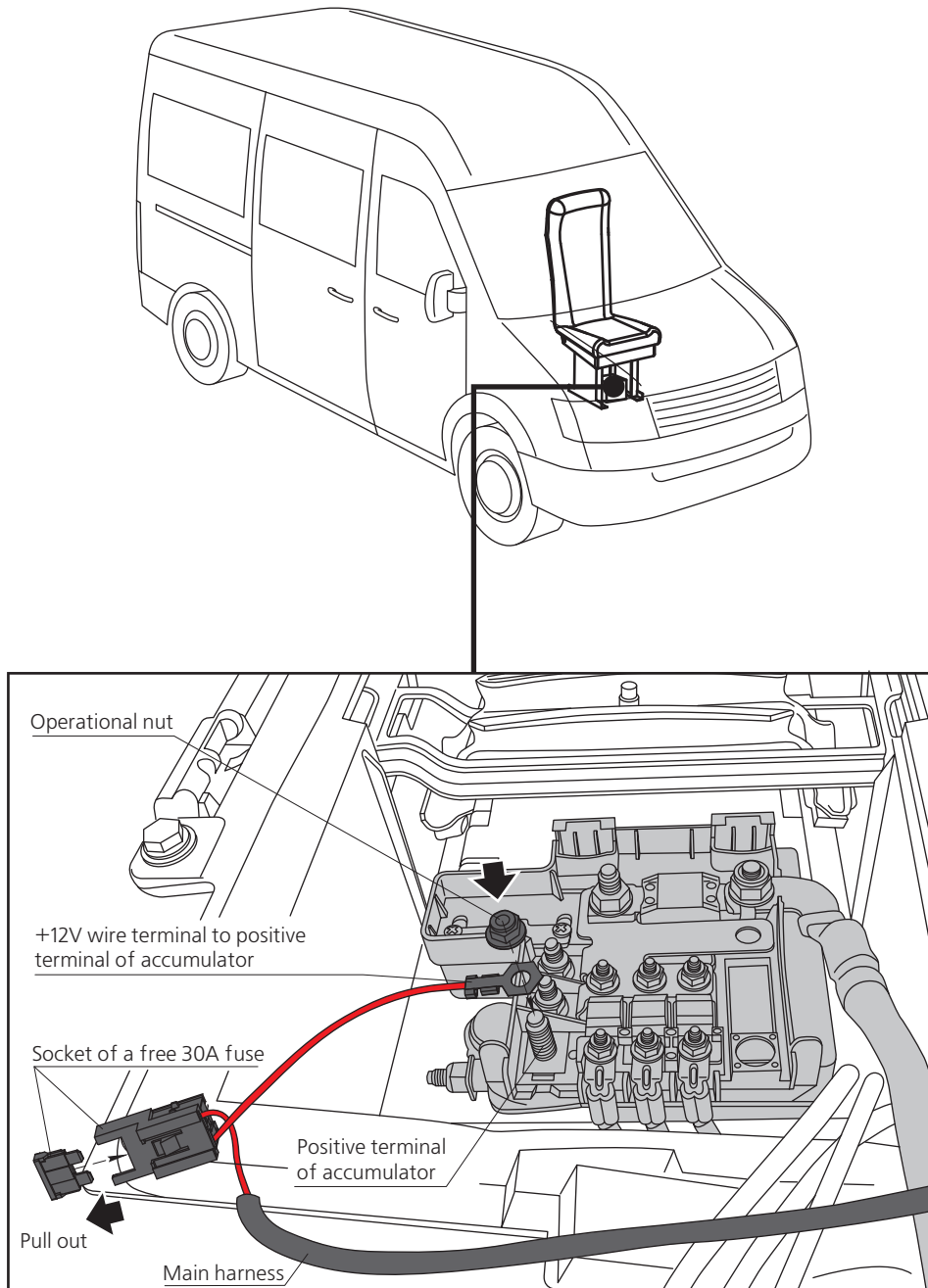

Connect the terminal of +12V red wire of the main harness to a free positive terminal of accumulator which is situated under the driver's seat. Fix the terminal of +12V harness wire with an accumulator's operational nut. Pull out 30A fuse from the fuse socket before connecting.

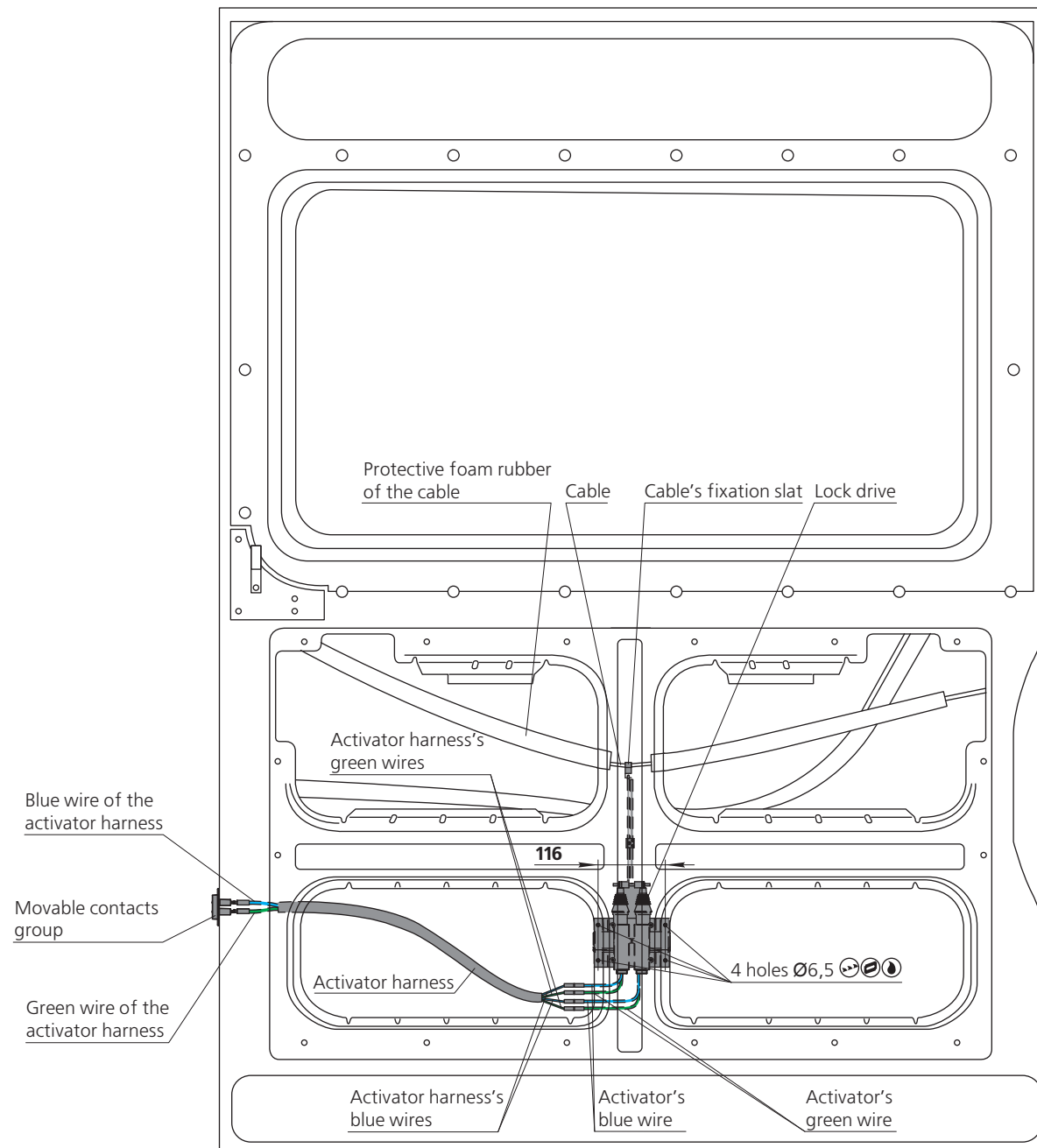

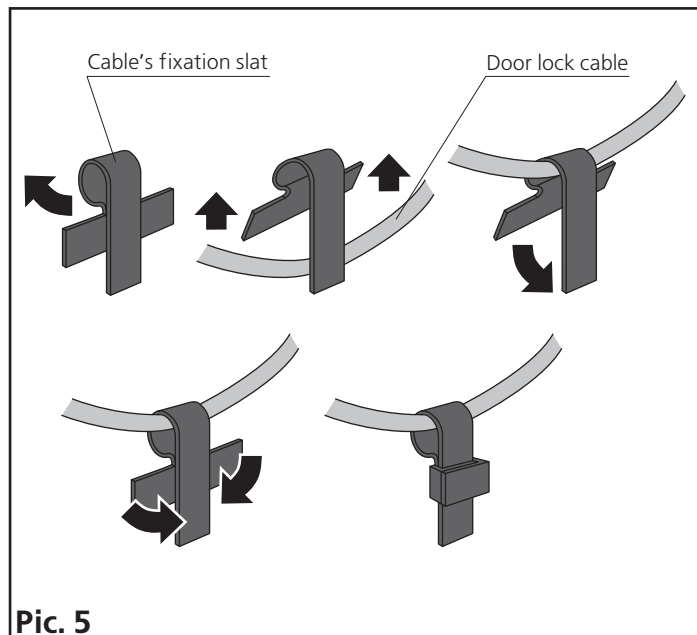
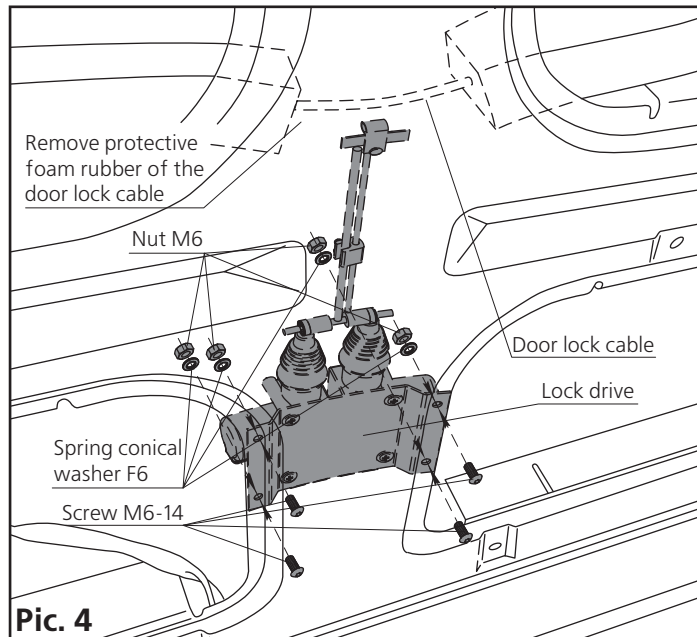

Cut off the protective foam rubber. Put the drive with the bracket to the door reinforcement and mark the holes for fixation. Drill 4 holes $\varnothing 6.5$ mm. Insert the cable into the door and fix it with 4 screws M6-14 with nuts M6 and spring washers.

Put the cable's fixation slat on the cable and fix it as shown in picture 5.

Connect the terminals of the lock drive's green wires to the terminals of the activator harness's green wires, and the terminals of the lock drive's blue wires to the terminals of the activator harness's blue wires as shown in the picture on page 13.



NOTE



Adjust the length of the drive link to make the cable as tight as possible. At the same time the locks of the sliding door must close safely.

To place the control button drill a hole $\varnothing 23$ mm on the dashboard where you will find it convenient to use. First connect the control button to the main harness socket (pic. 8) and then put it into the hole.

Mark the holes as shown in picture 6. Drill 2 holes $\varnothing 14$ mm (pic. 6). Connect activator's harness blue wire to the upper contact of the movable contacts group and the green wire to the lower contact as shown in the picture on page 13. Fix the movable contacts group with 2 self-driving screws 3.5-16 from the metalware set.

Open and close the door. Using the marks left by the contacts on the pillar, mark and drill a hole $\varnothing 20$ mm. Fix the fixed contacts group with 2 self-driving screws 3.5-16 (hidden) from the metalware set (pic. 7).

The wires are connected to the fixed contacts group in the following order: the blue wire - to the upper contact, the green wire - to the lower contact.

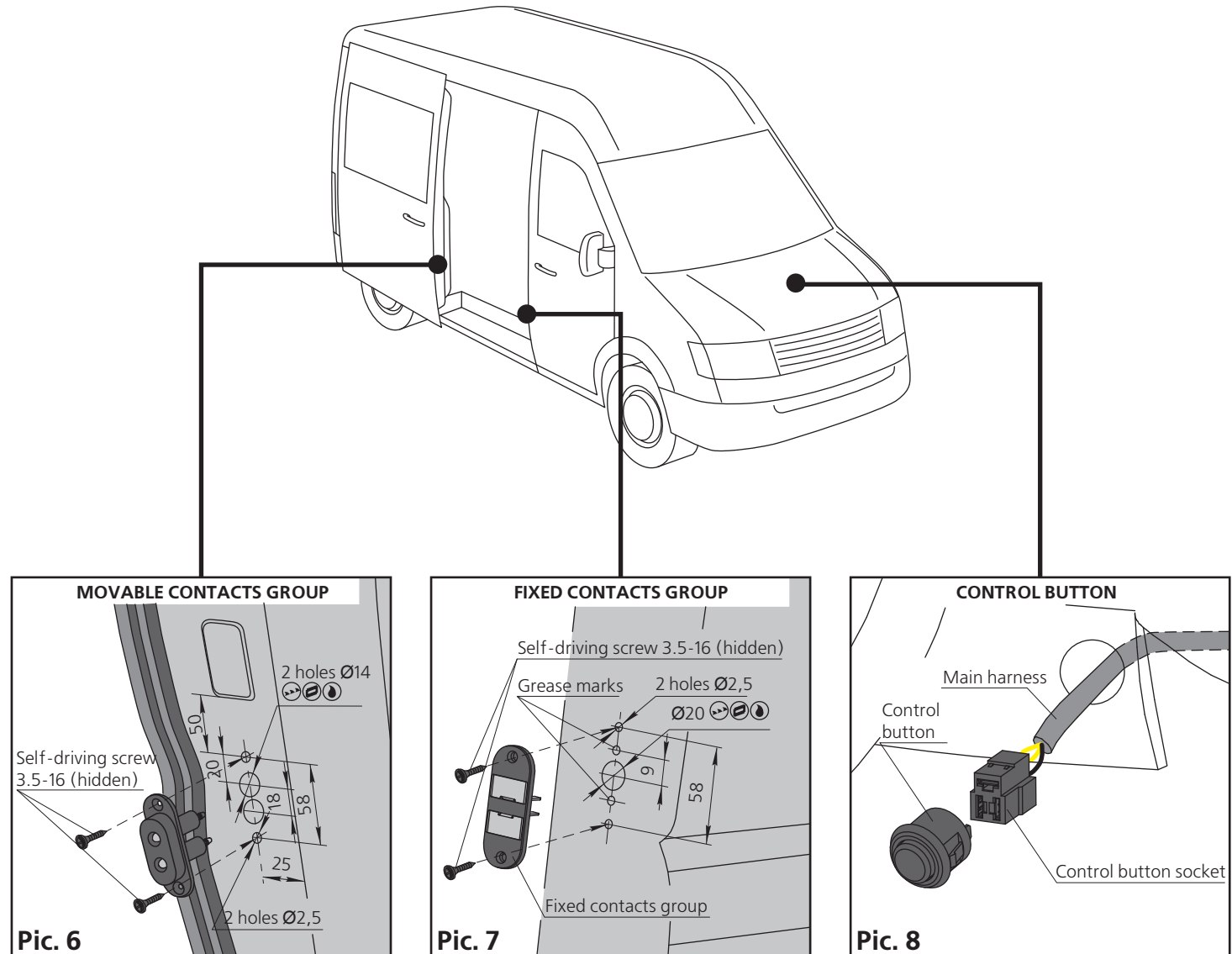

Pic. 6

Pic. 7

Pic. 8

VARIANT OF INSTALLING THE RACK AND PADDING H4 UP TO THE INTERNAL HANDLE FRAME

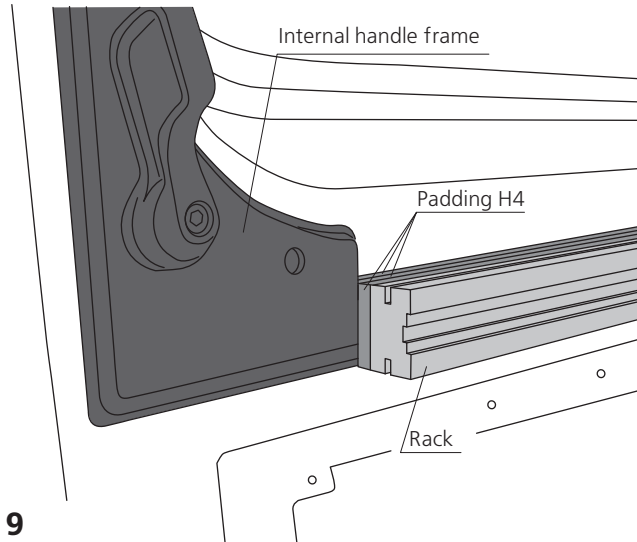

Pic. 9

VARIANT OF INSTALLING THE RACK AND PADDING H4 UP TO THE END OF THE DOOR

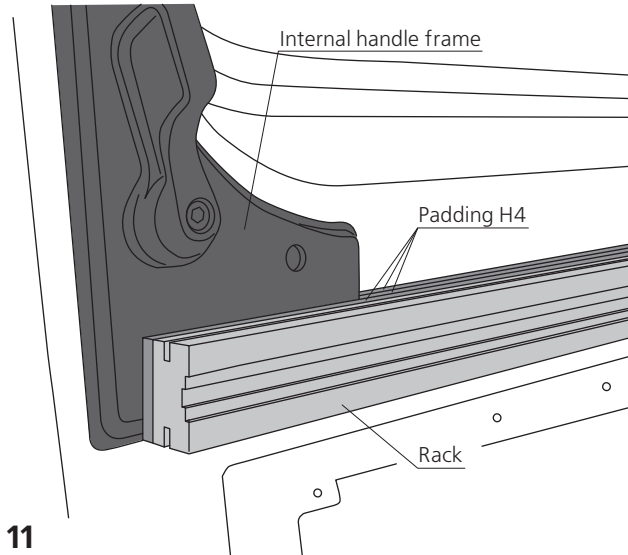

Pic. 11

VARIANT OF INSTALLING THE RACK AND PADDING H4 UP TO THE INTERNAL HANDLE FRAME

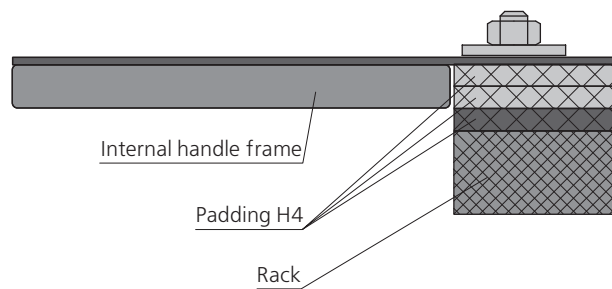

Pic. 10

VARIANT OF INSTALLING THE RACK AND PADDING H4 UP TO THE END OF THE DOOR

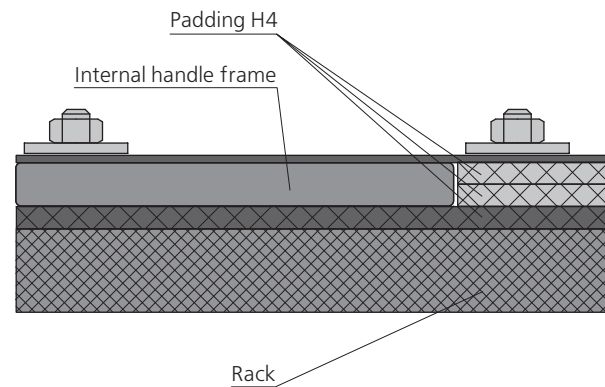

Pic. 12

2.9 INSTALLATION OF THE RACK AND PADDING ON THE DOOR

Depending on the chosen variant of installation saw off the rack as shown in the picture. The recommended length of the rack for Peugeot Boxer/Citroen Jumper is 1100 mm up to the internal handle frame (picture 9 and 10) and 1205 mm up to the end of the door (picture 11 and 12).

NOTE
The rack must be sawn only on the left side.

The rack is installed on 3 paddings H4 which must be sawn to the needed length beforehand.

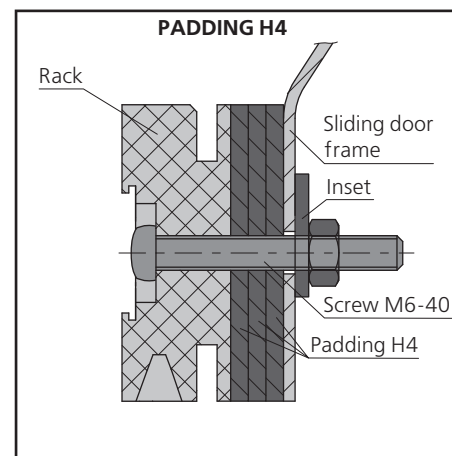
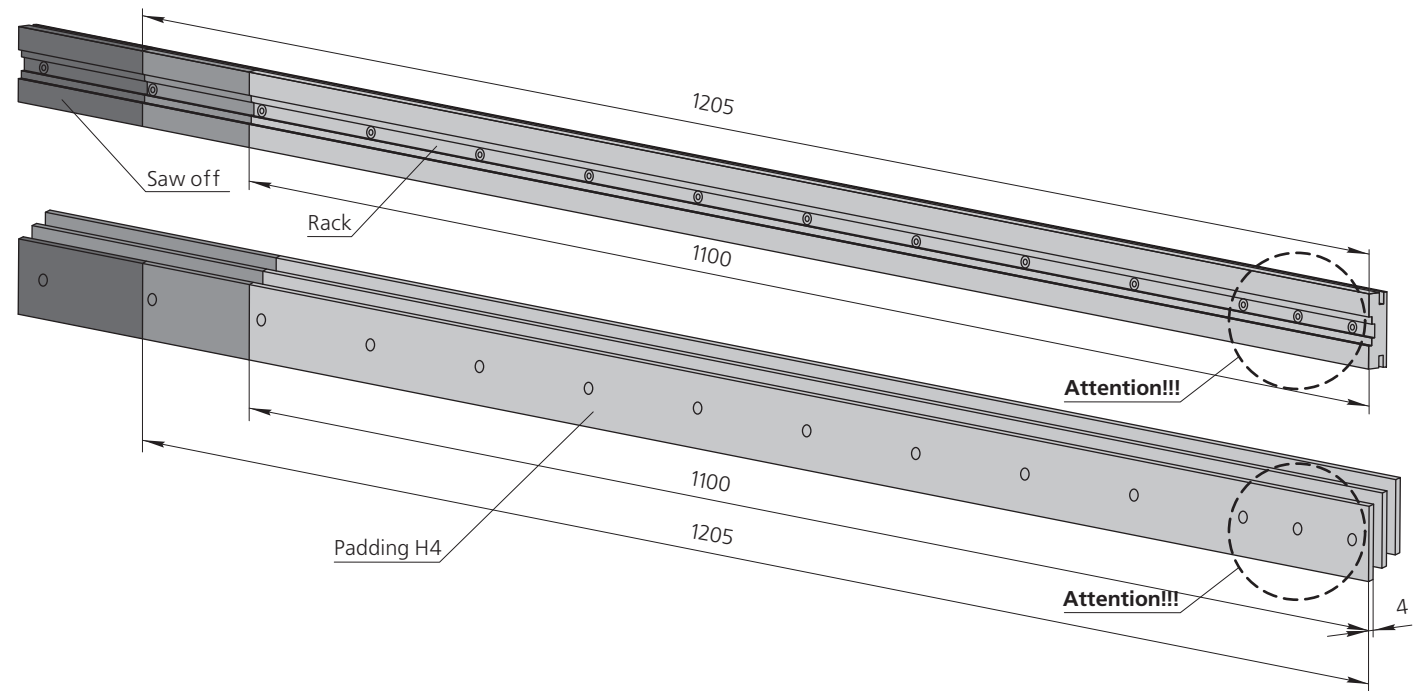

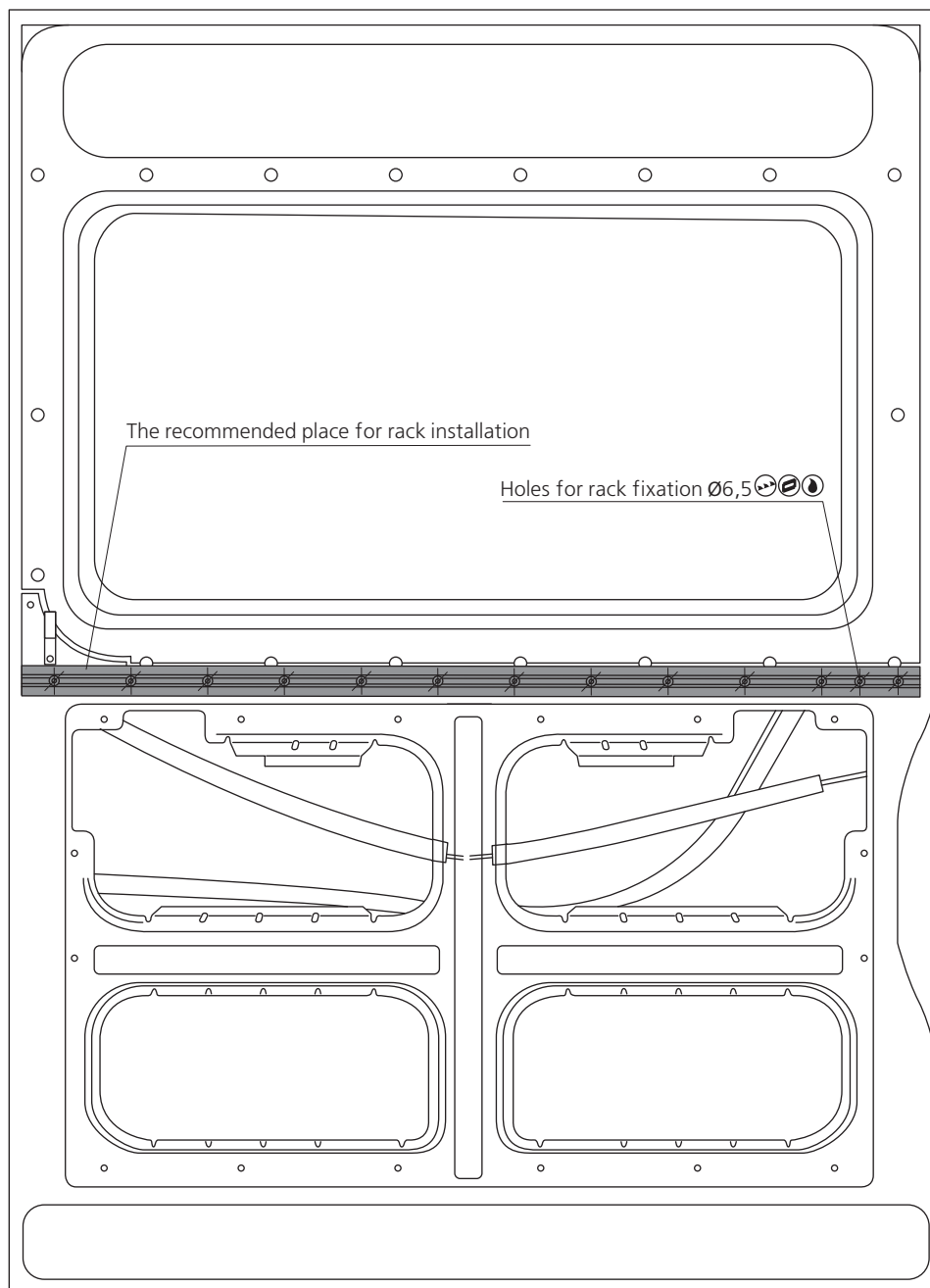

The recommended place for rack installation is shown in picture 13.

Put the rack to the recommended place as shown in the picture. The lower edge of the rack must be aligned with the lower edge of the internal handle frame. Mark the centres of fixation holes using the rack.

**NOTE**

The rack must necessarily be fixed through 4 back holes and 1 front hole. The middle part of the rack can be fixed through 1 hole.

Drill holes $\varnothing 6.5$ mm using the marks. The holes must be positioned in one line.

Fix the rack using metalware from the metalware set:

- Screws M6-40
- Plate nuts M6

**NOTE**

If operating mode of the drive is very intensive, you should use an inset under the rack. It is installed through 4 back fixation holes of the rack.

Pic. 13

3.1 BEARING SUPPORT INSTALLATION

Remove door seal in the area of bearing support installation (picture 14).

Put the bearing support to the body pillar (picture 15) so that rack plane A would be 8-10 mm above the bearing support plane B and space C between the bearing support and the rack would be 6-10 mm. Mark the centres of fixation holes on the bearing support with a marker.

Drill a hole $\varnothing 6.5$ mm for a screw M6-8 using the marks. Drill holes $\varnothing 5$ mm for rivets 4.8-12 from the metalware set (picture 16).

Fix the bearing support with a screw M6-8 only, then with rivets 4.8-12 from the metalware set (picture 17).

Cut off a part of the door seal from the inside so that the cutout would envelope the support's spacing collar.

Put the door seal back.

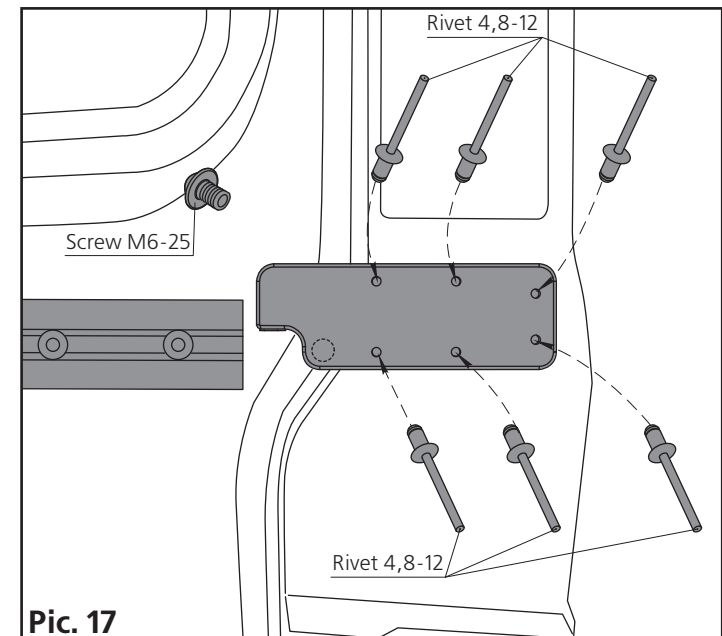
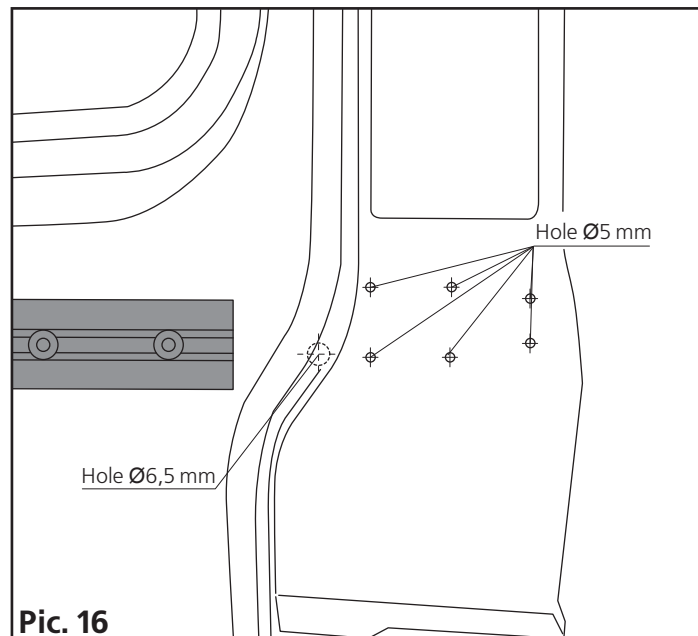
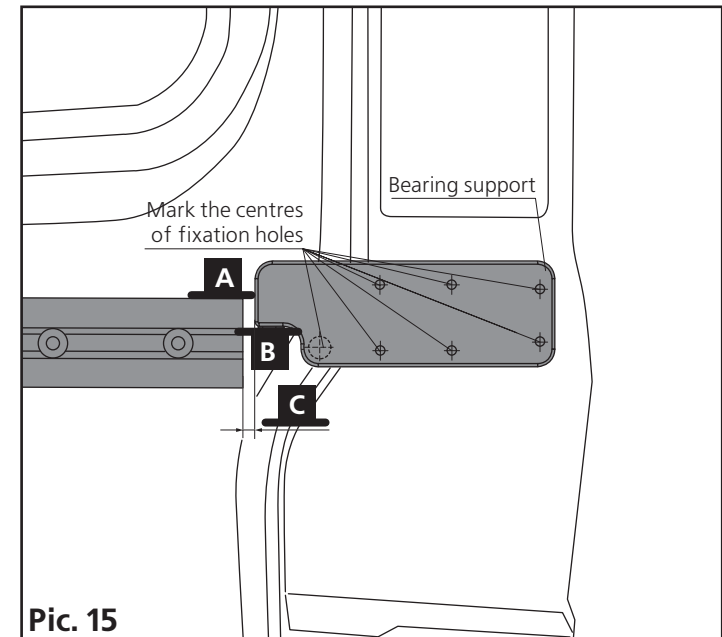
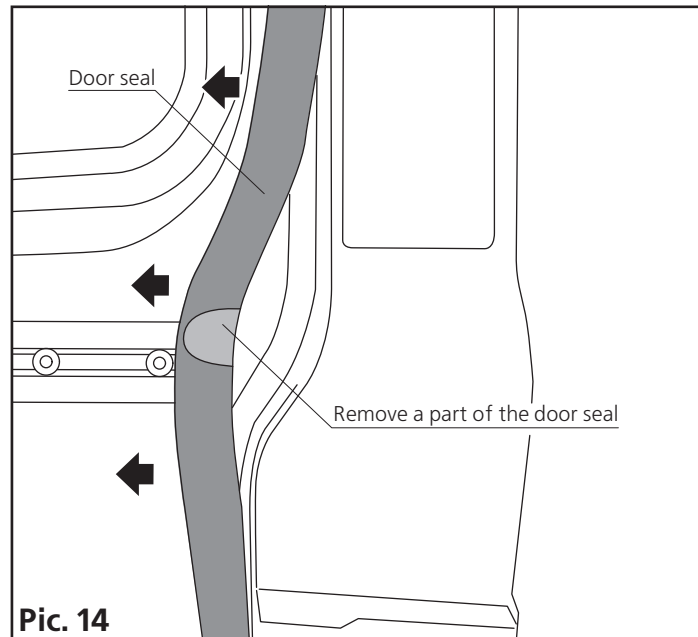

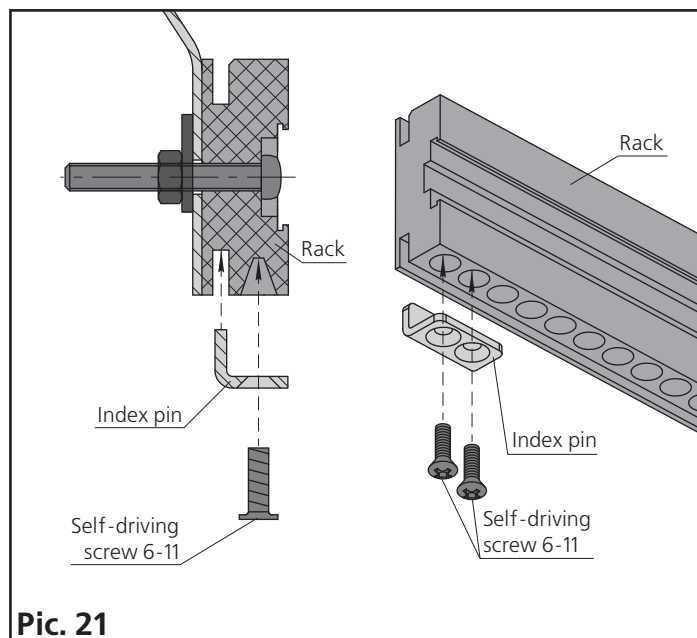
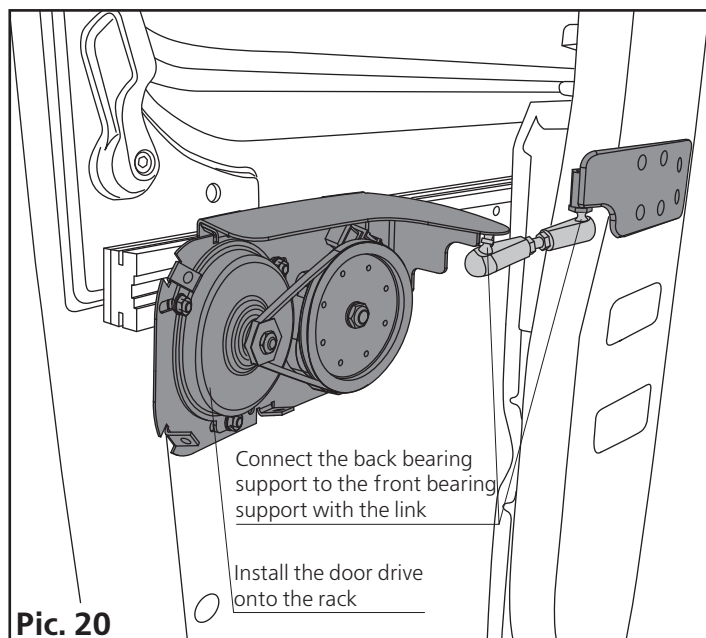
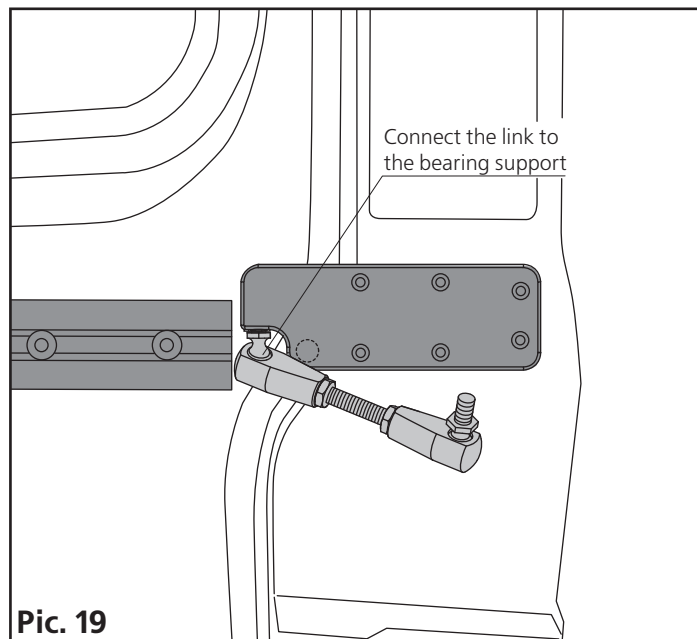
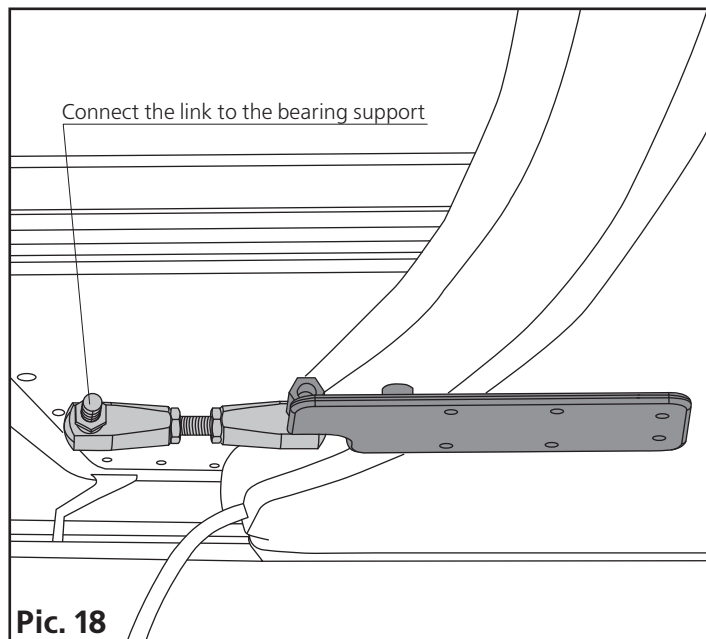

Connect the link to the bearing support (picture 18).

Close the door by hand.

Make sure that the parts of the bearing support and the link do not hinder to close the door easily.

Install the door drive onto the rack (picture 20).
Connect the link to the door drive.

Drill holes in the rack and install the index pin (picture 21).

Clear up the grooves of the rack from cuttings (picture 22).

Connect the drive to the controller.

Insert 30A fuse into the fuse socket. The controller will make a sound signal.

Start up the engine of the minibus.

Press the control button. The drive will close the door and the controller will be making sound signals for 1-2 sec. Then start opening cycle. The drive will open the door and slowly roll up to the index pin. After that the drive will be working in regular operation mode.



NOTE



Before removing the drive (if necessary) or switching off the controller, first remove 30A fuse from the fuse socket.

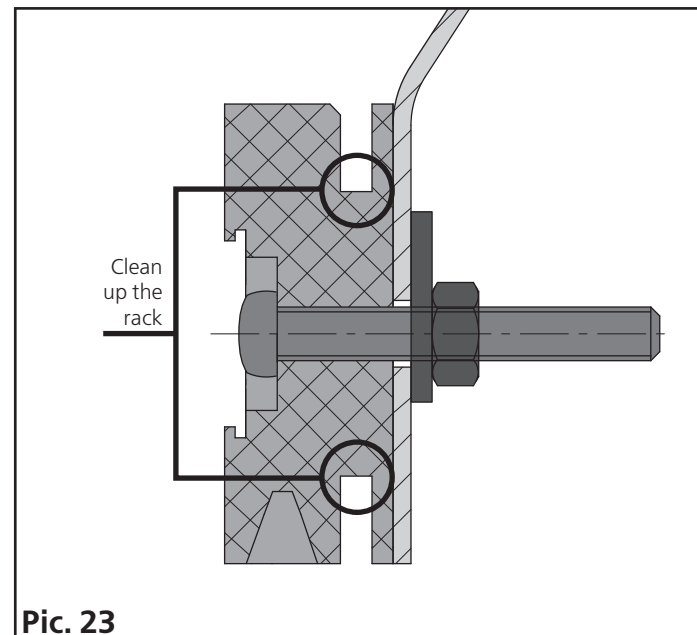
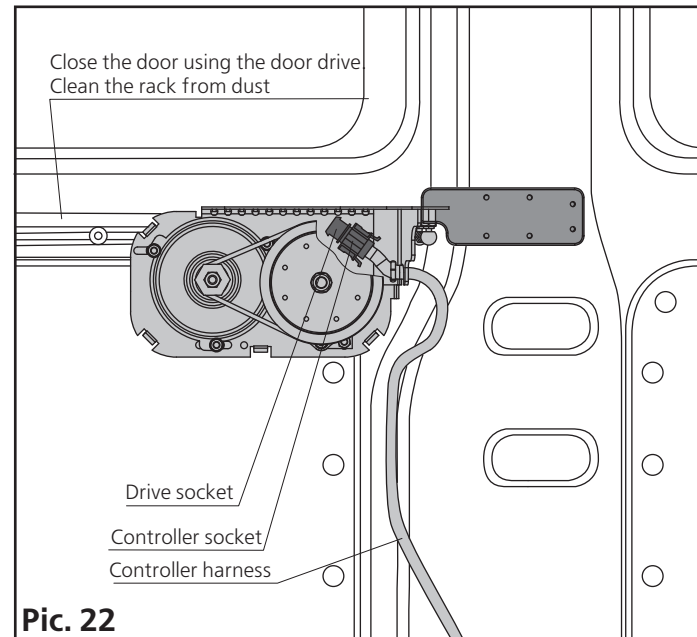

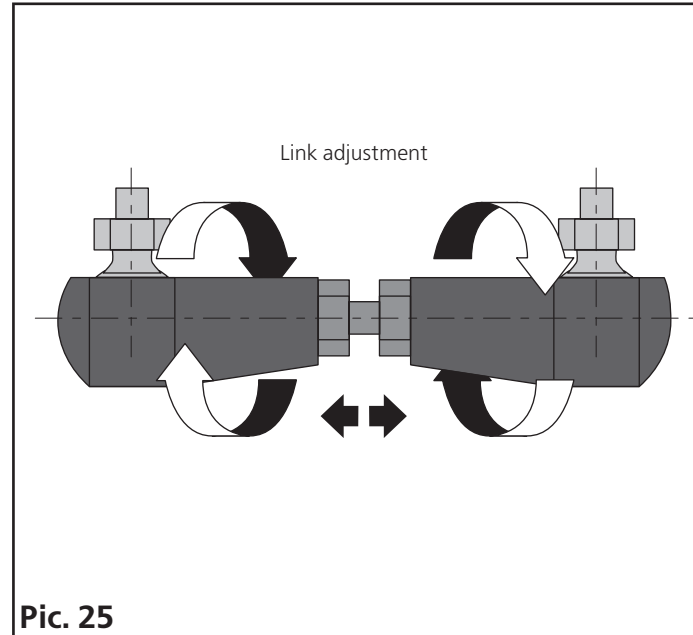
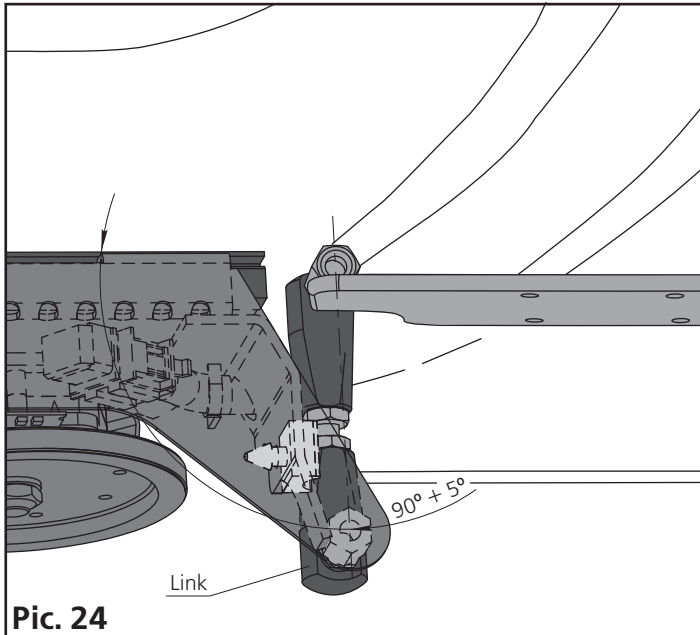

LINK ADJUSTMENT

The position of the link in normal closed position of the door is shown in picture 24.

Extend the length of the link so that the door would close tightly (picture 25).

If the link is installed correctly it must come up against the damper on the frame (picture 26).

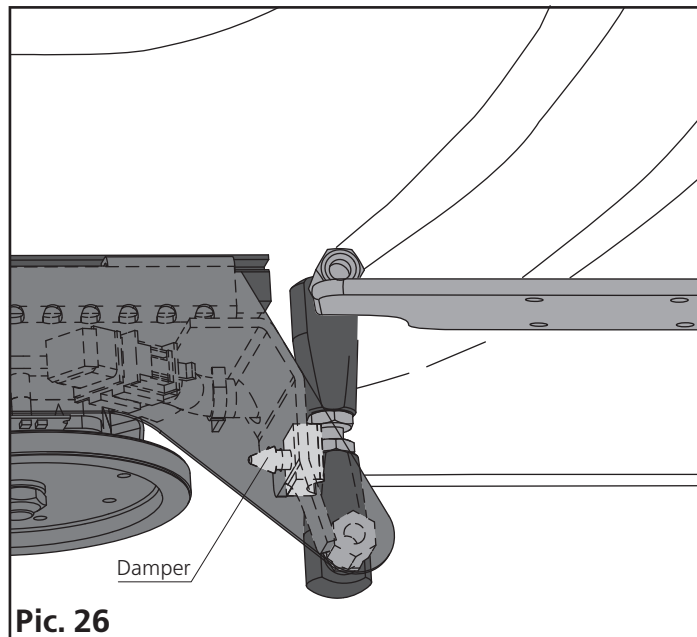

Fix the cover of the drive with 4 self-driving screws 4.2-13 from the metalware set (picture 27).

Cut the decorative edge to fit the rack (picture 28, 29).

Carefully insert the stripe into the rack groove as shown in pictures 28 and 29.

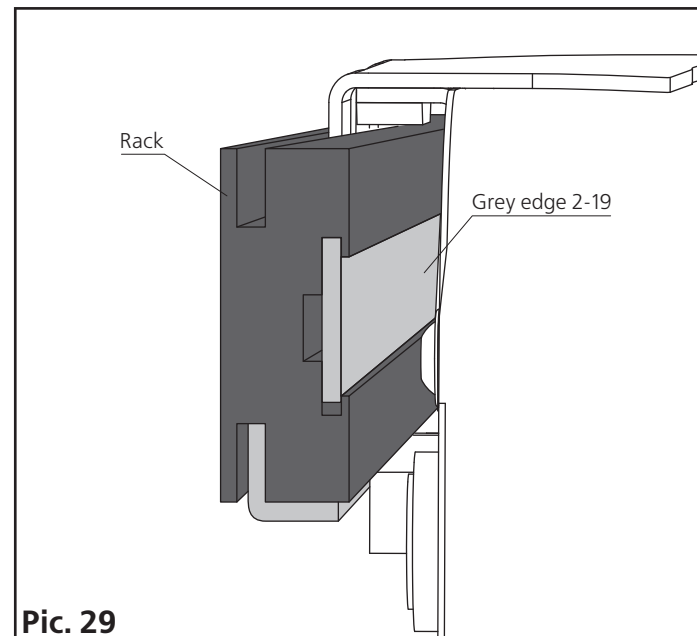
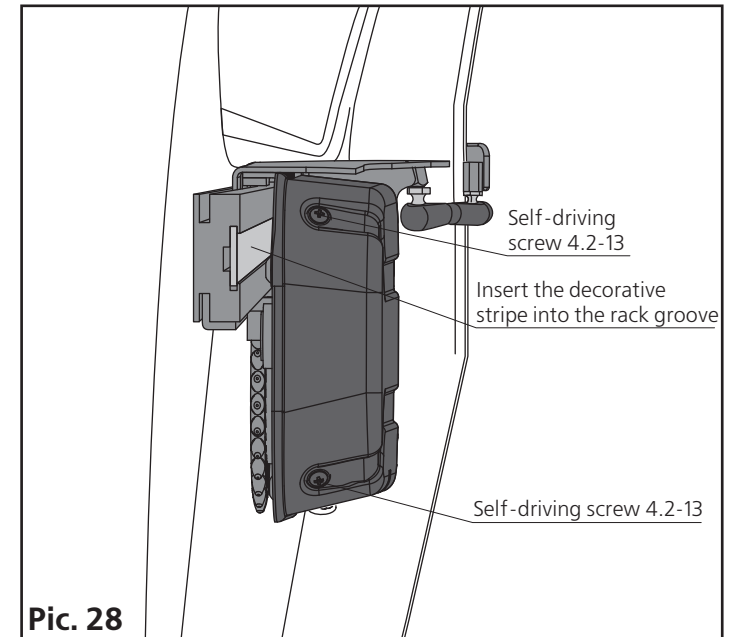
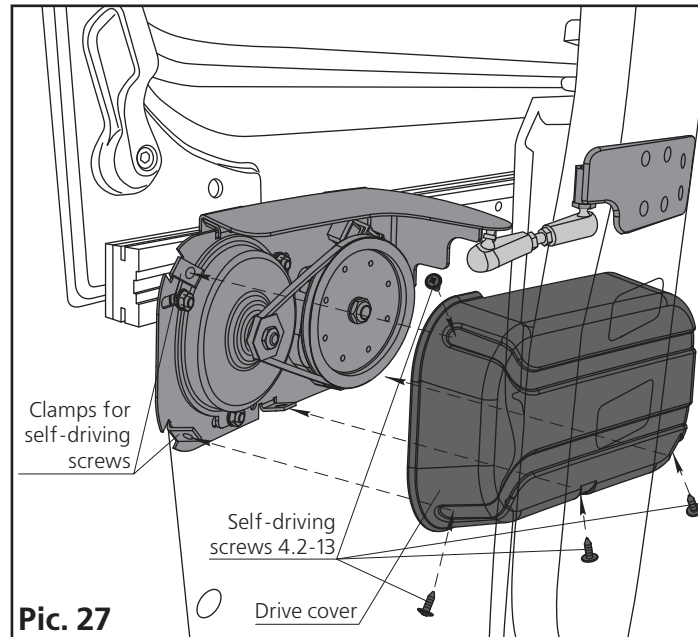

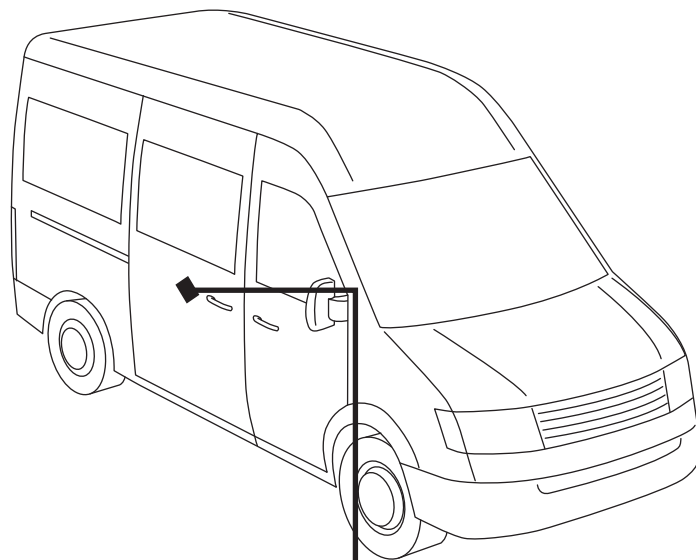

Place the information sticker on the outside panel of the sliding door so that it could be easily noticed.

Put the cover of the external handle to the opening/closing door handle. Mark and drill 2 holes $\varnothing 3$ mm. Fix the cover of the external handle on the opening/closing door handle with 2 self-driving screws 4.2-16 from the metalware set as shown in picture 30.

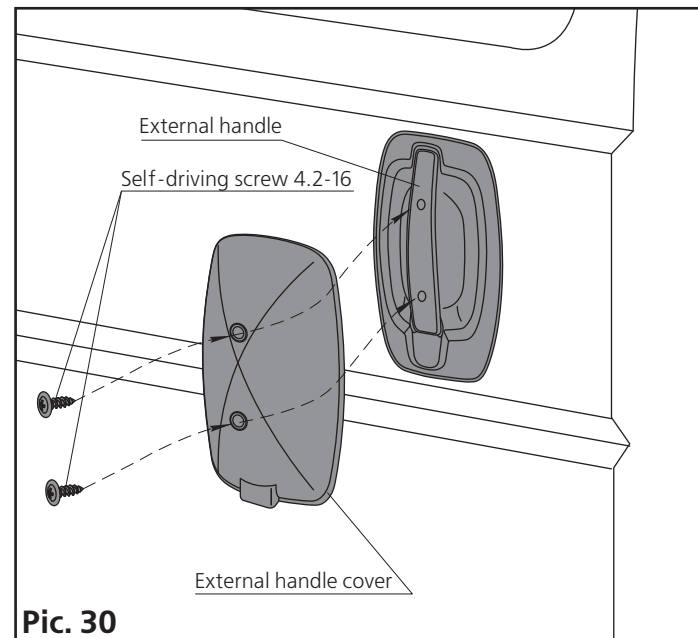

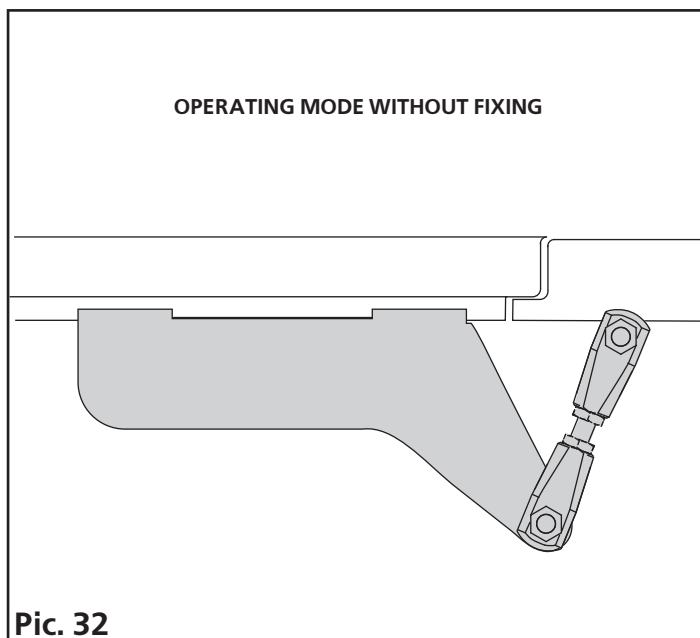
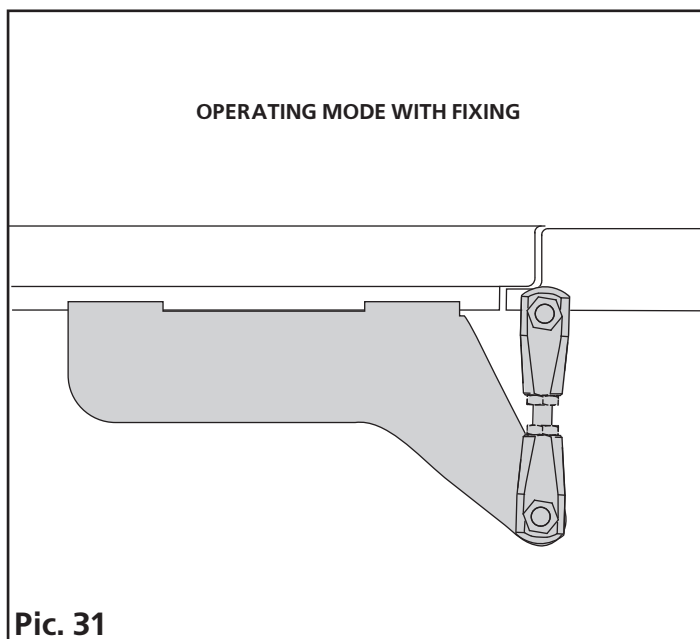
**OPENING AND CLOSING THE DOOR**

Press the control button for 0.5 sec. The door will start moving after you release the button.

STOPPING THE DOOR

Press the control button to stop the door while it is moving.

AUTOMATIC ROLL-BACK

If the door pushes against an obstacle while it is closing, it will stop automatically and roll back.

ADJUSTMENT OF THE WIDTH OF DOOR OPENING

Open the door. Adjust the needed width by hand. Press the control button for 10 sec. until you hear 2-times sound signal. Release the button. Now the drive will automatically remember the adjusted width of the opening.

OPERATING MODE OF SLIDING DOOR FIXING

The drive can operate in 2 modes:

1. With fixing (factory settings) picture 31).
2. Without fixing (picture 32).

To change the mode to operating without fixing press the control button for 15 sec. until you hear 3 long sound signals. Release the button.

RETURN TO FACTORY SETTINGS

Press the control button for 20 sec. until you hear 4-times sound signal. Release the button. All drive settings will return to factory settings.

**NOTE**

The drive settings will automatically return to factory settings in case of power outage.

EMERGENCY DOOR OPENING

FROM THE OUTSIDE (ONLY IN THE OPERATING MODE WITHOUT FIXING)

1. Remove the external cover (picture 33).
2. Pull the door handle and hold it (picture 34).
3. Pull the back side of the door (picture 34).
4. Open the door by the operational handle (picture 34).

FROM THE INSIDE

5. Turn the door handle and hold it (picture 35).
6. Move the drive to the left against the stop (picture 35).
7. Open the door by hand (picture 35).

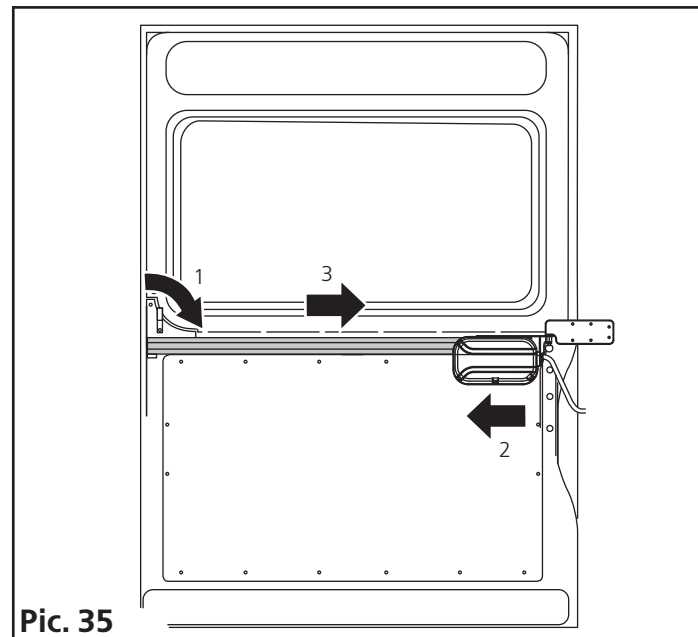
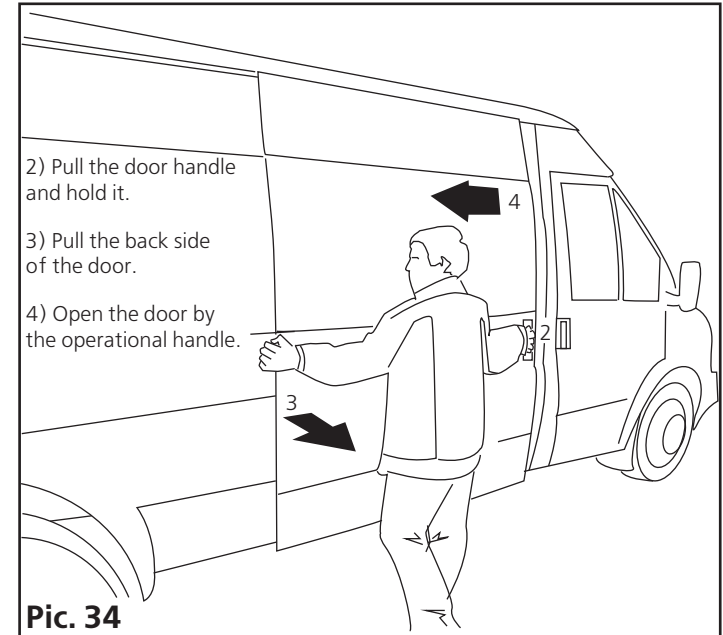
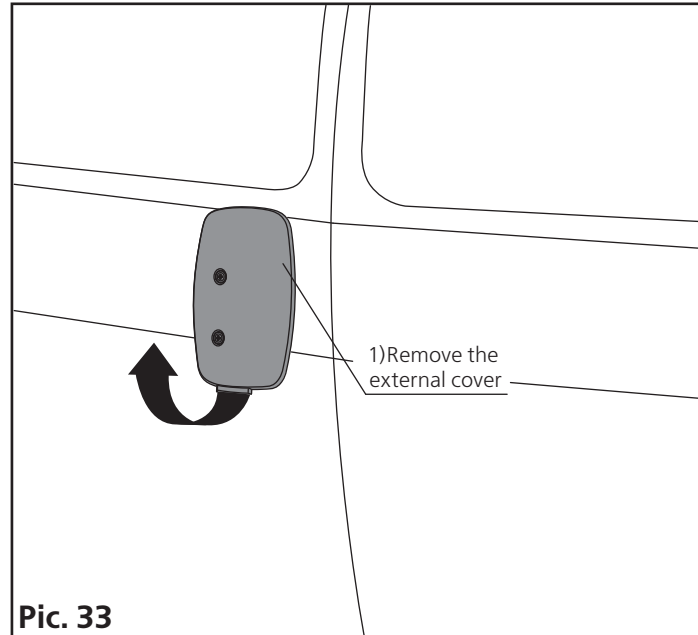

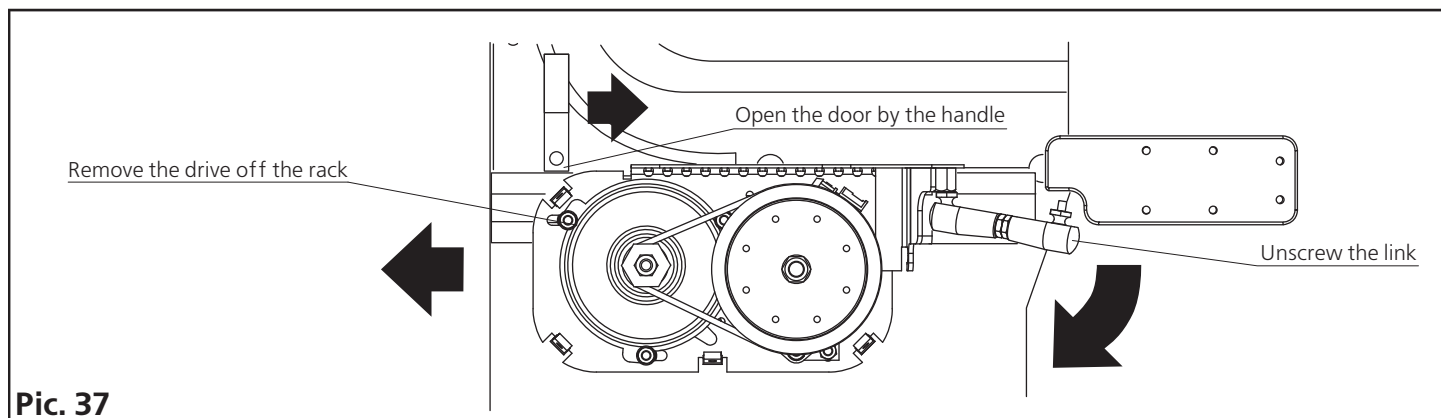
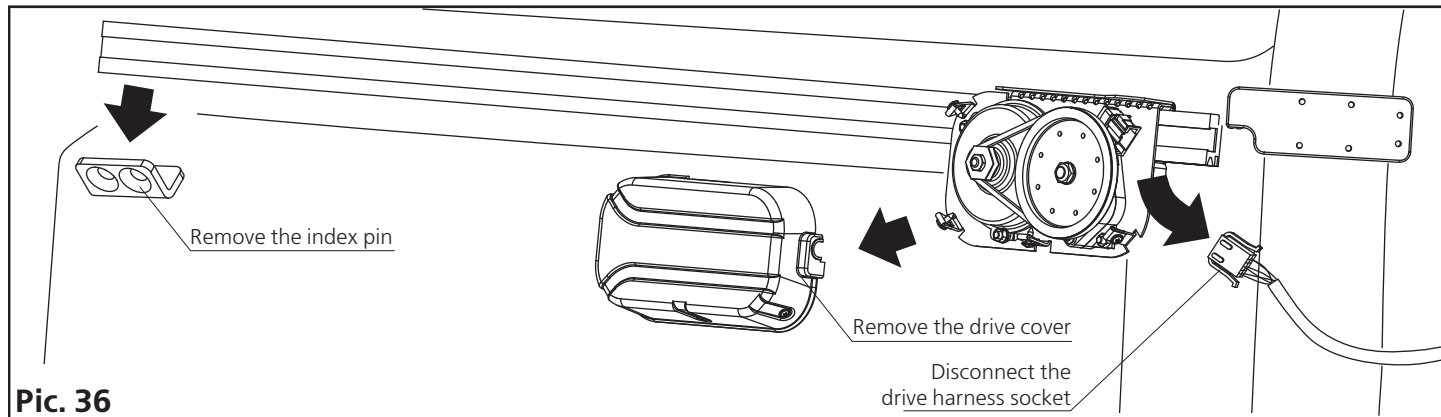
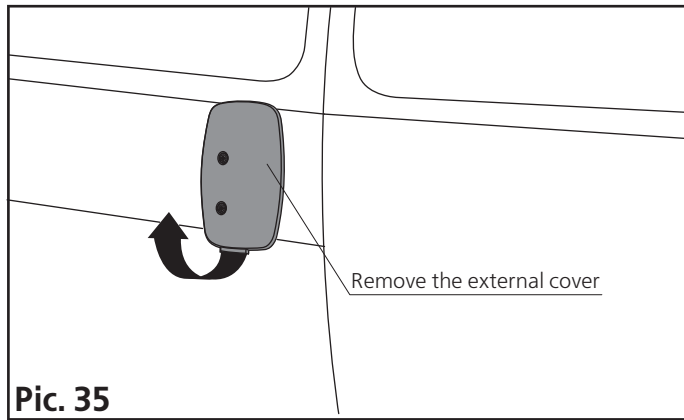

CHANGING TO MANUAL OPERATING MODE

1. Unscrew the external handle cover and open the door by hand (picture 35).
2. Remove the index pin (picture 36).
3. Remove the drive cover (picture 36).
4. Disconnect the drive harness socket (picture 36).
5. Unscrew the link (picture 37).
6. Remove the drive off the rack (picture 37).

